

BOARD OF REGENTS  
BRIEFING PAPER

**Agenda Item Title: University of Nevada School of Medicine - Approval of 4th Amendment to the Lease for 1703/1707 W. Charleston Blvd, Las Vegas**

**Meeting: March 3 - 4, 2016**

**1. BACKGROUND & POLICY CONTEXT OF ISSUE:**

Summary: The University of Nevada, Reno (UNR) and the University of Nevada School of Medicine (UNSOM) are seeking Board of Regents approval to amend an existing lease (Exhibit 1) with a 4<sup>th</sup> amendment for property located at 1703/1707 W. Charleston Blvd, Las Vegas. UNSOM and its Clinical Practice Plan, along with the University of Nevada Las Vegas (UNLV) Dental School, as sub-lessee, occupy the entire building.

The terms proposed in the 4<sup>th</sup> lease amendment have been reviewed and agreed upon in collaboration with the Nevada System of Higher Education (NSHE), UNR and UNLV. The facilities at 1703/1707 W. Charleston meet, in part, the immediate and near term requirements for UNLV and administration of the lease is proposed to transfer from UNSOM to UNLV in July of 2017 as part of the proposed medical school transition plan.

The 4<sup>th</sup> Amendment to the lease (Exhibit 2) addresses the following:

- Formally exercises existing Option Terms within the current lease extending the lease for 5 years starting June 1, 2016 and expiring May 31, 2021, pursuant to May 2015 notice letter.
- Formally assigns the lease to the Board of Regents from the UNSOM practice plan in anticipation of the medical school transition.
- Adds further clarification that the property can be utilized by any NSHE institution and that any such use does not constitute an assignment or subletting of the premises (i.e. does not require additional Landlord approval or renegotiation of terms).

Also, by exercising the Renewal Option, this retains an Option to Purchase 1703/1707 W. Charleston at terms within the existing contract that are beneficial to the NSHE and which provides future opportunities to UNLV.

The amendment has been reviewed and approved by Mary Dugan, UNR General Counsel, and by Nicholas Vaskov, System Counsel and Director of Real Estate Planning for the Nevada System of Higher Education.

**2. SPECIFIC ACTIONS BEING RECOMMENDED OR REQUESTED:**

University of Nevada, Reno President Marc Johnson requests approval to amend the existing Lease for 1703/1707 W. Charleston Blvd. allowing for the extension and assignment of Lease per the terms within the proposed 4<sup>th</sup> Amendment to the Lease.

**3. IMPETUS (WHY NOW?):**

Existing lease expires May of 2016.

**4. BULLET POINTS TO SUPPORT REQUEST/RECOMMENDATION:**

- UNLV supports the extension of the lease as part of the medical school transition.
- The terms and conditions of the renewal are desired by both UNR and UNLV.
- The proposed amendment allows for NSHE institutions' use of the property under the lease without additional approval of Landlord.
- By exercising the Renewal Option, this retains an Option to Purchase 1703/1707 W. Charleston at terms within the existing contract that are beneficial to the NSHE and which provides future opportunities to UNLV.

**5. POTENTIAL ARGUMENTS AGAINST THE REQUEST/RECOMMENDATION:**

None

**6. ALTERNATIVE(S) TO WHAT IS BEING REQUESTED/RECOMMENDED:**

Allow the lease to expire in May of 2016 and attempt to negotiate new terms, while in holdover tenancy, for the continued occupancy of the building for current operations and the planned transition of the medical school. This may be an expensive and risky approach with little or no benefit for the current or near terms plans for NSHE.

**7. COMPLIANCE WITH BOARD POLICY:**

- X Consistent With Current Board Policy: Title # 4 Chapter # 10 Section # 1.9
- Amends Current Board Policy: Title # \_\_\_\_\_ Chapter # \_\_\_\_\_ Section # \_\_\_\_\_
- Amends Current Procedures & Guidelines Manual: Chapter # \_\_\_\_\_ Section # \_\_\_\_\_
- Other: \_\_\_\_\_
- Fiscal Impact: Yes X No \_\_\_\_\_
- Explain:** Annual rent expense of \$878,460

Exhibit 1

07/27/05 09:58 FAX

BRUCE A. LESLIE, CHTD.

002

Original Copy  
Copy 5 Of 6 Copies

**LEASE AGREEMENT**

**V.A. CLINIC ASSOCIATES,**

a Nevada limited partnership,

as Landlord

and

**UNIVERSITY OF NEVADA SCHOOL OF MEDICINE  
MULTI-SPECIALTY GROUP PRACTICE SOUTH, INC.,**

a Nevada corporation

as Tenant

Dated JANUARY 20, 1998

TABLE OF CONTENTS

	Page
Basic Lease Provisions .....	iii
1. PREMISES .....	1
2. TERM .....	2
3. PAYMENT OF RENT .....	2
4. RENT .....	2
5. LEASE CONTINGENCY .....	3
6. TAXES AND ASSESSMENTS .....	4
7. INSURANCE .....	5
8. UTILITIES .....	7
9. PARKING AREA .....	8
10. USE .....	8
11. REPAIRS .....	9
12. ALTERATIONS .....	11
13. EMINENT DOMAIN .....	11
14. DAMAGE AND DESTRUCTION .....	12
15. DEFAULT BY LANDLORD .....	13
16. TENANT'S DEFAULT .....	13
17. INDEMNIFICATION, RELEASE AND LIENS .....	17



18. NON-DISTURBANCE; SUBORDINATION AND FINANCING ..... 18

19. SURRENDER OF PREMISES ..... 19

20. CONSTRUCTION OF PREMISES; COOPERATION ..... 19

21. NOTICES ..... 19

22. ATTORNEY'S FEES ..... 20

23. ASSIGNMENT AND SUBLETTING ..... 20

24. ACCESS ..... 20

25. HOLDOVER ..... 20

26. INSOLVENCY OF TENANT ..... 21

27. SURRENDER OF LEASE ..... 21

28. SALE OF PREMISES BY LANDLORD ..... 21

29. SIGNS ..... 21

30. MISCELLANEOUS ..... 21

SIGNATURES ..... 23

EXHIBITS:

- A LEGAL DESCRIPTION
- B SITE PLAN
- C PROVISIONS REGARDING LANDLORD AND TENANT'S WORK AND LANDLORD'S CONSTRUCTION ALLOWANCE
- D ESTOPPEL CERTIFICATE
- E-1 SUBORDINATION, ATTORNMENT AND NON-DISTURBANCE AGREEMENT
- E-2 CONSENT TO SUB-LEASE, ATTORNMENT AND NONDISTURBANCE AGREEMENT

BASIC LEASE PROVISIONS

1. Landlord: V.A. Clinic Associates,  
a Nevada limited partnership
2. Landlord's Address For Payment of Rent and Notices: V.A. Clinic Associates  
2300 W. Sahara, Ste. 640  
P.O. Box 23  
Las Vegas, NV 89102  
Attn: Mark L. Fine  
Copy to: Peter C. Bernhard, Esq.  
Bernhard & Leslie, Chtd.  
3980 Howard Hughes Pkwy.  
Suite 550  
Las Vegas, NV 89109
3. Tenant: University of Nevada School of Medicine  
Multi-Specialty Group Practice South, Inc.
4. Tenant's Address For Notices: Jeffrey W. Wyatt  
2040 W. Charleston Blvd., Ste. 400  
Las Vegas, NV 89102  
Copy to: Craig H. Edgecumbe, Esq.  
2780 Skypark Drive, Ste. 325  
Torrance, CA 90505-5350
5. Land: That certain approximate 2.2 acre parcel of land situated in the City of Las Vegas, County of Clark, State of Nevada, as more particularly described in Exhibit A.
6. Improvements: A two (2) floor office building (the "Building") containing 44,824 rentable square feet of Floor Area, and 38,377 usable square feet of Floor Area, and all other improvements as shown on Exhibit B.
7. Term: Seven (7) years.
8. Estimated Commencement Date: July 15, 1998
9. Option Term: Two (2) option terms, each for Five (5) years.
10. Initial Term Base Rent Per Month: Fifty Five Thousand Dollars (\$55,000.00) during the initial seven year term.
11. Option Term Base Rent Per Month: 1st option term = \$60,500.00  
2nd option term = \$66,550.00
12. Permitted Uses: Any use consistent with an "A" class building.

The Basic Lease Provisions set forth above are incorporated into and made a part of the following Lease. Each reference in this lease to any of the Basic Lease Provisions shall mean the respective information above and shall be construed to incorporate all of the terms provided under the particular Lease paragraph pertaining to such information. In the event of any conflict between the Basic lease Provisions and the provisions of the Lease, the latter shall control.

LEASE AGREEMENT

THIS LEASE, executed this 20<sup>th</sup> day of JANUARY, 1998, by and between V.A. Clinic Associates, a Nevada limited partnership (hereinafter called "Landlord") and University of Nevada School of Medicine Multi-Specialty Group Practice South, Inc., a Nevada corporation, (hereinafter called "Tenant"), is entered into upon the terms and conditions set forth below.

1. **Premises.** The premises ("premises") leased hereunder are located in the City of Las Vegas, County of Clark, State of Nevada, commonly known as 1703 West Charleston Blvd. The premises consist of (i) an existing building (the "building") having a total of approximately 44,824 square feet of total Floor Area, and 38,377 square feet of usable Floor Area, (ii) the parcel of real property described on Exhibit "A", and (iii) any and all other improvements thereon and appurtenances thereto, including without limitation, all vehicular parking areas and improvements, as shown on the Site Plan depicted on Exhibit "B".

Notwithstanding anything to the contrary contained herein, Landlord and Tenant recognize and agree that Landlord is the Lessee of an approximate 1/2 acre portion of the parking area under that certain Ground Lease dated August 16, 1978, between Dodd Smith as Ground Lessor and Landlord's predecessor-in-interest as Ground Lessee. Landlord hereby covenants and warrants to Tenant that Landlord shall at all times during the term of this Lease, including any option terms exercised hereunder, keep said Ground Lease in full force and effect so as to ensure that Tenant will have available at all times during the term hereof, the entire parcel of real property described in Exhibit A.

As used in this Lease, the term "Floor Area" with respect to any leasable area in the building shall be determined by adding (a) the aggregate number of square feet of floor space of all floor levels therein, measured from (i) the outside faces of all perimeter walls thereof; (ii) the outside face of any interior wall; and (iii) the building and/or lease line adjacent to any entrance to such leasable area (there being no deduction or exclusion from Floor Area by reason of columns, ducts, interior restrooms or other interior components); and (b) any area occupied by restrooms, lobby, utility rooms, janitorial rooms and interior stairways.

Notwithstanding the foregoing, Landlord reserves for its own use the right to locate one (1) antenna tower on a portion of the premises, to be constructed, maintained and operated by Landlord or Landlord's designee (including the right of ingress and egress over the premises for construction and maintenance), provided that the location, maintenance and operation of said tower does not deprive Tenant of the use and occupancy of the building, driveways, or any parking spaces or areas included



within this Lease. Said antenna tower shall be for cellular or other similar electronic transmissions and shall not interfere with any of Tenant's business operations. Landlord shall provide liability and casualty insurance at its sole expense in regard to said antenna. Tenant shall not unreasonably withhold its consent to the location of said antenna.

2. **Term.** The initial term of this Lease shall be for a period of seven (7) full years commencing the earlier to occur of December 1, 1998 or the date upon which Tenant is first obligated to pay \$55,000.00 per month rental as provided in Paragraph 4 hereof, and expiring on November 30, 2005. Subject to Landlord's Work to be performed as set forth in Exhibit C, Tenant shall be entitled to exclusive possession of the premises upon full execution and delivery of this Lease.

Tenant is hereby given the option to extend the term hereof on all the provisions contained in this Lease, except for fixed rent, which shall be determined pursuant to Paragraph 4 hereinbelow, for two (2) consecutive periods of five (5) years following expiration of the initial lease term; provided that on the date the applicable extended term is to commence Tenant shall not be in default under this Lease (after receipt by Tenant of any notice required under the terms of this Lease and beyond any cure period provided for in this Lease). To exercise the first such option to extend, Tenant shall give Landlord written notice of exercise of such option at least one (1) year prior to the expiration of the initial term. To exercise the second such option to extend, Tenant shall give Landlord written notice of exercise of such option at least one (1) year prior to the expiration of the first option term. Notwithstanding anything to the contrary contained in this Lease, if Tenant fails to give any such notice of exercise within the time provided herein, Tenant shall not be deemed to have waived the applicable option to extend unless and until Landlord shall have given Tenant written notice of such failure and such failure continues for a period of twenty (20) days after Tenant's receipt of such notice. In the event that on the date the applicable extended term is to commence Tenant shall be in default under this Lease (after receipt by Tenant of any notice required under the terms of this Lease and beyond any cure period provided for in this Lease), at Landlord's option, the extended term shall not commence and this Lease shall thereupon expire. All references in this Lease to the term shall mean the initial term, and upon the exercise of any option pursuant to this paragraph, the initial term as extended by any such options.

3. **Payment of Rent.** Tenant hereby covenants and agrees to pay to Landlord the "fixed rent" as set forth in Paragraph 4 below. The payment of rent hereinafter set forth shall begin on the first day of the month next following occupancy by Tenant of the building. Rent shall be payable to Landlord at the address set forth on page iii of this Lease, or at such other address designated by Landlord.

4. **Rent.** Tenant shall pay to Landlord annual fixed rent, payable in monthly installments in advance on the first day of each month throughout the term as set forth below. The first month's rent shall commence on the first day of the month next following occupancy by Tenant of any portion of the building and shall be calculated based upon the usable Floor Area first occupied by Tenant multiplied by \$1.43 per square foot of usable Floor Area. The rent payable on the first day of each month thereafter through and including November 30, 1998 shall also be calculated based upon the



usable Floor Area then occupied by Tenant multiplied by \$1.43 per square foot of usable Floor Area; provided, however, Tenant shall pay not less than \$27,500.00 monthly rent from and after July 15, 1998, and not less than \$55,000.00 monthly rent from and after December 1, 1998, so long as Landlord's Work shall have been completed at the time and in the manner required under the provisions of Exhibit "C" of this Lease and further provided that the Landlord's Allowance for Tenant's Work (as such terms are defined in Exhibit "C") shall have been allocated for the use of Tenant as required in said Exhibit "C".

So long as all of the provisions set forth above in this Paragraph 4 have been complied with by Landlord, Tenant shall pay \$55,000.00 monthly rent each month from and after December 1, 1998, through and including the entire initial term of this Lease, except during any option terms. Rent during the first option term shall be the sum of \$60,500.00 per month payable from and after December 1, 2005 through the expiration or termination of the first option term. Rent during the second option term, if any, shall be \$66,550.00 per month. There shall be no increases in rent during the initial term, or any option term other than as immediately set forth above.

**5. Lease Contingency.** The satisfaction of the following condition shall constitute a condition precedent to (i) the commencement of the term of this Lease (ii) Tenant's acceptance of the premises, and (iii) Tenant's obligations under this Lease: not later than ninety (90) days after Tenant submits plans and specifications to the appropriate governmental agency, Tenant shall have procured all required building, signage, conditional use and other permits, licenses and approvals necessary to enable Tenant to perform Tenant's Work, to install Tenant's desired signs, to fixturize the premises and to conduct its intended business on the premises. In the event such condition is not satisfied within the time period set forth herein, because a governmental agency has not timely approved the issuance of any such permits, licenses or approvals, Tenant shall have the right to terminate this Lease by written notice delivered to Landlord within five (5) business days after any such non-timely approval. Tenant shall diligently apply for and pursue to completion, using its best efforts, the obtaining of such approvals and shall not voluntarily withdraw its applications or not provide required information to a governmental agency. The foregoing condition shall be deemed waived by Tenant upon the acceptance by Tenant of any sums from Landlord's Allowance for Tenant's Work. If for any reason Landlord shall not deliver possession of the premises to Tenant on or before April 15, 1998, due to no act or omission of Tenant, such failure shall not affect the validity of this Lease but in such case Tenant shall not be obligated to pay rent until the first day of the month after the premises shall have been delivered to Tenant and the July 15, 1998 and December 1, 1998 dates for commencement of 50% and 100% of rent, respectively, shall be advanced on a day-for-day basis until the premises shall have been delivered to Tenant, provided, however, that if Landlord shall not have delivered possession of the premises as required herein on or before August 1, 1998, Tenant may, by notice in writing to Landlord within ten days thereafter, cancel this Lease, in which event the parties shall be discharged from all obligations hereunder. "Possession of the premises" (as used in the foregoing sentence) shall be deemed delivered to Tenant when (1) Landlord's Work is substantially completed, (2) the building utilities are ready for use in the premises, and (3) Tenant has reasonable access to the premises, and (4) Landlord



receives approval by the appropriate governmental agency for the portion of the Premises which has been substantially completed.

6. **Taxes and Assessments.** Tenant shall be responsible for and shall pay all real property taxes and assessments (whether special or general), rental business tax, and surcharges, including any increases thereon, levied or assessed against the premises, including, without limitation, any tax or excise on rent, or levy in any way relating to environmental protection, or any other real property tax, levy, assessment or other charge of any nature whatsoever imposed by any governmental authority and levied upon or assessed against the premises, including any such tax, fee or assessment levied or assessed in lieu of such real property taxes (all of which are herein referred to as "taxes and assessments"). For the purpose of this Paragraph, the term "rental business tax" as used herein shall include any business tax imposed upon Landlord, as an owner of real property, by the State of Nevada, or any political subdivision thereof, which is based upon or measured in whole or in part by amounts charged or received by Landlord under this Lease, provided that Tenant shall only pay the amount of such rental business tax that would be payable by Landlord if the premises were the only property of Landlord. In the event said taxes and/or assessments are not paid as required hereunder, and such failure continues for ten (10) days after Tenant's receipt of notice thereof from Landlord, Landlord may, in addition to all other remedies permitted in this Lease, pay such taxes and assessments for Tenant, bill Tenant therefor and add an additional charge equal to any penalty and interest that are then due. Such sums shall then be due and payable with the next payment of fixed rent.

Tenant shall pay in a timely manner all property taxes and assessments on the furniture, fixtures, equipment, merchandise and other property of Tenant at any time situated or installed in the premises, and in addition, on improvements in the premises made or installed by Tenant subsequent to the commencement of rent hereunder. If at any time during the term of this Lease any of the foregoing are assessed as a part of the real property of which the premises are a part, Tenant shall pay to Landlord upon demand the amount of such additional taxes as may be levied against said real property by reason thereof. For the purpose of determining said amount, figures supplied by the County Assessor as to the amount so assessed shall be conclusive.

In no event shall Tenant be required to pay (a) any portion of Landlord's general income, franchise, inheritance, estate or gift taxes, or (b) any business license tax or fee imposed against Landlord which is generally applicable to all business owners or operators in the city, county or state in which the premises are located.

Landlord shall furnish Tenant with copies of all applicable bills pertaining to taxes and assessments, until such bills are in Tenant's name and sent to Tenant.

Landlord agrees that the definition of taxes and assessments shall specifically exclude any increase in the tax bill occurring after the date of this Lease resulting from a reassessment of the premises because of a sale, assignment, or other transfer of the premises or any part thereof.



Tenant shall have the right at its expense to contest the rate, legality or validity of any tax or assessment to be paid by Tenant, but no such contest shall be carried on or maintained by Tenant after such taxes or assessments become delinquent unless Tenant shall (i) pay the amount involved under protest, or (ii) procure and maintain a stay of all proceedings to enforce collection, forfeiture and sale and provide for payment thereof together with all penalties, interest, costs and expenses by the deposit of a sufficient sum of money or by a good and sufficient undertaking or other means required or permitted by law to accomplish such stay. At the request of Tenant, Landlord will execute or join in the execution of any instrument or documents reasonably required by Tenant in connection with any such contest. Any refund obtained shall be the property of Tenant.

7. **Insurance.** At all times during the term of this Lease, Landlord shall maintain in full force and effect with insurance companies licensed to do business in the State of Nevada and otherwise satisfactory to Landlord in its reasonable discretion one or more policies including the following coverages:

A. "All risk" (as such term is customarily used and accepted in the insurance industry) property insurance on the building and parking area improvements as shown on Exhibit B, earthquake insurance at Landlord's option, loss of rental income insurance at Landlord's option, sprinkler leakage (if the building contains sprinklers) insurance in such form and with such covered perils as Landlord deems appropriate in its reasonable discretion insuring the premises in an amount equal to the full replacement value thereof. All proceeds shall belong to and be the sole property of Landlord, and Tenant hereby assigns to Landlord or its nominee all of Tenant's right, title and interest thereto.

B. Plate glass insurance covering the full replacement value of plate glass, frames and lettering thereon within and part of the building to include a safety glazing material endorsement, any deductible provisions of which are solely for the account of Landlord.

Landlord shall have the right to maintain blanket policies with the foregoing limits provided that the amount of insurance coverage is not reduced. A certificate of insurance evidencing the insurance coverage required of Landlord hereunder shall be delivered to Tenant within thirty (30) days after satisfaction or waiver of the lease contingency set forth in paragraph 5, above, and shall provide that the policy may not be cancelled or modified without at least thirty (30) days prior written notice to Tenant. The certificate shall also provide that Tenant shall receive notice of renewal of such insurance policy annually not later than ten (10) days prior to the policy's scheduled expiration date. If Tenant receives notice that the insurance required to be obtained by Landlord pursuant to this Paragraph is to be cancelled or will expire, and if prior to ten (10) days before the effective date of cancellation or expiration Tenant has not received written notice from the insurance carrier or agent that the policy will be extended or a new policy substituted in its place, then Tenant shall have the right without notice, but shall have no obligation, to procure such substitute insurance insuring the premises as Tenant in its discretion deems reasonable, and deduct such premiums from the fixed rent. Landlord agrees that all insurance policies shall contain an endorsement stipulating that Tenant, its officers,



directors, employees and agents are included as additional insureds thereon, and that such insurance shall not be cancelable without ten (10) days prior written notice to Tenant.

Beginning prior to the commencement of Tenant's Work and continuing at all times during the term of this Lease, Tenant shall maintain in full force and effect with insurance companies licensed to do business in the State of Nevada one or more policies evidencing the following coverage a certificate of which shall be submitted to Landlord prior to Tenant's undertaking Tenant's Work:

A. Comprehensive general liability insurance insuring all operations within the building and parking area, independent contractors, products and completed operations and contractual liability arising from the operation, possession, maintenance or use of the premises or areas immediately adjacent thereto with limits of liability of not less than \$2,000,000 each person, and \$5,000,000 each occurrence for bodily injury, and personal injury and \$100,000 each occurrence for property damage.

B. Comprehensive automobile liability insurance insuring all owned, nonowned and hired vehicles used in the conduct of Tenant's business and operated upon or parked upon the parking areas with limits of liability of not less than \$2,000,000 each person and \$5,000,000 each occurrence for bodily injury and \$100,000 each occurrence for property damage.

C. Standard Form Workers' Compensation and Employer's Liability Insurance covering all Tenant's employees for injury or illness suffered in the course of or arising out of their employment providing Statutory Workers Compensation benefits and Employer's Liability Limits of not less than \$100,000.

D. Fire, extended coverage, vandalism and malicious mischief, and other perils at Tenant's discretion, insurance in an amount equal to the full actual cash value of all furniture, fixtures, stock and equipment, including fixtures and improvements and betterments installed by Tenant in the premises, any deductible provisions of which are solely for the account of Tenant.

E. Business Interruption insurance covering at least sixteen (16) weeks of interruption of Tenant's business per year.

A duplicate original or certificate of all such policies shall be delivered to Landlord at least fifteen (15) days prior to the time such insurance is first required to be carried by Tenant and thereafter at least fifteen (15) days prior to the expiration or cancellation of any such policy. In the event Tenant fails at any time during the term of this Lease to obtain such insurance or to provide such evidence thereof, and such failure continues for ten (10) days after Tenant's receipt of notice thereof from Landlord, Landlord shall have the right but not the duty to procure such insurance and Tenant shall pay to Landlord the costs and expenses thereof as additional rent when the next payment of fixed rent is required to be made.



Tenant agrees that all insurance policies shall contain an endorsement stipulating that Landlord, its officers, employees and agents are included as additional insureds thereon, except Workers' Compensation Insurance, and that such insurance shall not be cancelled without thirty (30) days written notice to Landlord. All policies of insurance obtained by Tenant shall contain the following provision: "Such insurance as afforded by this policy for the benefit of Landlord shall be primary as respects any claims, losses or liabilities arising out of the use of premises by Tenant or by Tenant's assignees, sub-tenants, and permittees, and any insurance carried by Landlord shall be excess and non-contributing."

Landlord and Tenant hereby waive any rights each may have against the other on account of any loss or damage occasioned to Landlord or Tenant, as the case may be, or their respective property, the premises, or its contents, arising from any risk generally covered by all risk insurance in Nevada; and the parties each, on behalf of their respective insurance companies insuring the property of either Landlord or Tenant against any such loss, waive any right of subrogation that it may have against Landlord or Tenant, as the case may be.

Tenant agrees to pay to Landlord upon demand the amount of any increase in premiums for insurance against loss by fire that may be charged during the term of this Lease on the amount of insurance to be carried by Landlord on the premises resulting from Tenant doing any act in or about the premises which does so increase the insurance rates, whether or not the Landlord shall have consented to such act on the part of Tenant.

All policies of insurance required under this Lease shall be written by companies of generally accepted responsibility and credit, licensed to do business in Nevada. Such insurance companies shall at all times have a policyholder's rating of "B+" or better and financial rating of Class X or better as reflected in the most recent edition of "Best's Insurance Guide".

In lieu of providing individual policies of insurance, the insurance protection required of Tenant may be provided in the form of blanket policies of insurance covering the premises and other properties; provided, however, certificates of insurance evidencing the coverage required hereunder shall be provided as herein required and any such blanket policy shall provide that the amount of insurance required under this Lease shall not be prejudiced in any manner by other losses covered by the policy.

8. **Utilities.** Tenant agrees to pay timely all charges for gas, heat, sewer, power, electricity, telephone, storm drain, water service and water meter charges and all other utility charges (but not including any hook up or connection fees or charges) which may accrue with respect to the premises during the term of this Lease whether the same be charged or assessed at flat rates, measured by separate meters or prorated by the utility company. Landlord shall in no event be liable to Tenant for any interruption in the service of any such utilities to the premises, however such interruption may be caused, and this Lease shall continue in full force and effect despite any such interruptions, provided, however, that if such interruption is caused by any act, or non act, of Landlord and continues for five (5) consecutive business days, Tenant shall be entitled to a day-for-day rent abatement (pro-rated as to



the portion of the premises affected) until such utilities shall be restored.

**9. Parking Area.** Landlord grants to Tenant the exclusive right to use the parking area (as hereinafter defined) for itself, its employees, agents, customers, invitees and licensees.

As used herein, "parking area" means all areas, improvements and facilities of every kind and nature in and around the premises utilized for access and perimeter roads, truck passageways and platforms therein; parking areas, loading docks, special easement areas, landscaped areas and berms, signs and markers; and lighting and poles.

Landlord represents and warrants that the common area will at all times contain no less than two hundred fifteen (215) parking spaces which are available for Tenant's exclusive use. Landlord shall not make and shall not allow anyone to make any changes to the shape, size, location, layout, nature or extent of the parking area as such parking area exists as of the date of this Lease, including, without limitation, (i) the construction of any buildings, signs, kiosks or other structures, whether temporary or permanent, anywhere upon the parking area; or (ii) the erection of any barriers or fences or other alterations affecting parking or access in or to the parking area.

Landlord at all times during the term shall perform major repairs to the parking area. Prior to occupancy of the premises by Tenant, Landlord shall resurface and restripe the parking area. Landlord shall perform any major repairs necessary to the parking area on a prompt basis, in no event later than 30 days after notice to Landlord of the need of such major repair. A major repair shall be any repair which costs more than Two Thousand Five Hundred Dollars (\$2,500). Tenant shall be responsible for all subsequent restriping of the parking area during the initial term of the lease and for all other repairs to the parking area.

**10. Use.** Tenant shall have the right to occupy and use the premises for office, research, child care, laboratory educational facilities, pharmacy, health clinic, retail and related office uses. Any other lawful use must be approved by Landlord, which approval will not unreasonably be withheld. Nothing contained in this Lease shall be deemed or construed to impose any affirmative obligation on Tenant to make any particular use of the premises, or any use thereof at all; and nothing contained in this Lease shall be deemed or construed to require Tenant to keep the premises open for the conduct of business during any particular hours, or any particular days, or at all. Landlord warrants and represents that no covenant of exclusive use or use restriction currently in effect restricts the use of the premises. Tenant shall not allow any activity to be conducted on the premises or store any material on the premises which will increase premiums for or violate the terms of any insurance policy maintained by or for the benefit of Landlord. Tenant acknowledges that neither Landlord nor its agents or employees have made any representations or warranties as to the suitability or fitness of the Premises for the conduct of Tenant's business or for any other purpose.

For purposes of this Lease, "Hazardous Materials" means any substances defined as "hazardous



*substances*" in the Comprehensive Environmental Response, Compensation and Liability Act of 1980, as amended, 42 U.S.C. §9601-9657; the Hazardous Materials Transportation Act of 1975, 49 U.S.C. §1801-1812; the Resource Conservation and Recovery Act of 1976, 42 U.S.C. §6901-6987; or any other federal, state, or local statute, law, ordinance, code, rule, regulation, order, or decree regulating, relating to, or imposing liability or standards of conduct concerning hazardous materials, waste, or substances now or at any time hereafter in effect (collectively, "*Hazardous Materials Laws*").

Tenant will not cause or permit the storage, use, generation, or disposition of any Hazardous Materials in, on, or about the Premises by Tenant, its agents, employees, or contractors. Tenant will not permit the Premises to be used or operated in a manner that may cause the Premises or the project to be contaminated by any Hazardous Materials in violation of any Hazardous Materials Laws. Tenant will immediately advise Landlord in writing of (1) any and all enforcement, cleanup, remedial, removal, or other governmental or regulatory actions instituted, completed, or threatened pursuant to any Hazardous Materials Laws relating to any Hazardous Materials affecting the Premises; and (2) all claims made or threatened by any third party against Tenant, Landlord, or the Premises relating to damage, contribution, cost recovery, compensation, loss, or injury resulting from any Hazardous Materials on or about the Premises. Without Landlord's prior written consent, Tenant will not take any remedial action or enter into any agreements or settlements in response to the presence of any Hazardous Materials in, on, or about the Premises.

Tenant will be solely responsible for and will defend, indemnify and hold Landlord, its agents, and employees harmless from and against all claims, costs, and liabilities, including attorney fees and costs, arising out of or in connection with Tenant's breach of its obligations in this Article 10. Tenant will be solely responsible for and will defend, indemnify, and hold Landlord, its agents, and employees harmless from and against any and all claims, costs, and liabilities, including attorney fees and costs, arising out of or in connection with the removal, cleanup, and restoration work and materials necessary to return the premises and any other property of whatever nature located in, on, or about the building, to their condition existing prior to the introduction of Hazardous Materials by Tenant, its agents, employees or contractors. Tenant's obligations under this Article 10 will survive the expiration or other termination of this Lease.

11. **Repairs.** Landlord warrants and shall deliver a report that confirms that at the time possession of the premises is delivered to Tenant, the shell, structure and roof of the premises shall be in a good and watertight condition, and the heating, ventilating and air conditioning and elevator systems located in the premises shall be in good working order and condition, in accord with the Landlord's Work. In addition, and without reducing Landlord's obligations under the preceding sentence, Landlord hereby assigns to Tenant all assignable warranties of materialmen, subcontractors and equipment manufacturers in effect, if any, applicable to work performed upon or materials and equipment incorporated in or installed upon the premises.

In addition, Landlord shall, at its sole expense:



(a) Perform all major repairs to the roof, including the roof membrane, structure and supports, such that water tight conditions shall be maintained at all times during the term; provided, however, Landlord shall be entitled to invoice Tenant (with backup supporting documentation), and Tenant agrees to pay said invoice within thirty (30) days after receipt thereof, once each calendar year for all such roof repairs performed by Landlord, such invoice not to exceed twenty-five hundred dollars (\$2,500.00) in any single calendar year; (SEE PAGE 10A)

(b) Perform all major repairs to the building shell (all repairs in excess of \$2,500 shall be considered major), replacements and alterations necessary or appropriate, in the reasonable judgment of Tenant, to keep the following in compliance with all laws, ordinances, rules, regulations and orders, and in good order, condition and repair:

(1) The exterior walls, interior load bearing walls, and interior roof structural columns;

(2) The foundations, floor slab and structural supports;

(3) The gutters, downspouts and roof drain system;

(4) All wiring, plumbing, pipes, conduits and other water, sewage, utility and sprinkler fixtures and equipment (including, without limitation, all connections with and components of any private sewage system serving the premises) which are located within the slab of the premises, beneath the premises or between the building and the main public utility lines;

(5) The main HVAC components, including automatic temperature controls, electrical transformers, main panel boards and electrical switch gear, and elevator systems.

(c) Landlord shall also perform all maintenance and make all repairs and replacements which result from any structural failure of the premises or which become necessary or appropriate at any time because of any act, negligence or default under this Lease of Landlord, its agents, employees, licensees or contractors.

Except as herein provided, Tenant covenants and agrees at Tenant's own cost and expense to keep the interior of the building and parking areas, and each and every part thereof, including, without limitation, all plumbing and electrical conduits, wiring, fixtures and pipes and all sewers, floors, flooring, walls, lighting, air conditioning and heating systems, ceilings and all other parts thereof in good condition and repair at all times during the term hereof and to make or perform promptly any and all maintenance or repairs (but not repairs related to the items in subparagraph (b)(1)-(5) above) or renewals or replacements which may at any time be necessary or proper to put and keep the interior of the building and parking areas in good condition and repair, and to keep the interior and parking areas and all appurtenances thereto in a good, clean, safe and wholesome condition at all times during said

provided, further, in the event Landlord provides an entirely new roof for the building (with an appropriate minimum 20 year bondable warranty) during the term hereof, then Landlord's repair obligation with respect to said new roof shall be governed by the provisions of subparagraph (b) immediately below, and in such event, the provisions of this Section 11(a) shall be void, and of no further force and effect with respect to this lease;



term. Tenant shall pay for all janitorial services for the premises. Tenant shall obtain and maintain a preventative maintenance contract with contractors licensed and qualified to service and maintain the HVAC system and elevator systems within the building, in accord with manufacturer's specifications for such equipment and systems installed within the building.

12. **Alterations.** Notwithstanding anything to the contrary contained in this Lease, Tenant may perform non-structural alterations with respect to the premises as necessary for Tenant's permitted use of the premises, without prior approval of Landlord; provided, however, Tenant agrees to comply with all requirements of local governmental ordinances regulating said alterations, including the obtaining of all required permits. All alterations shall be performed by contractors licensed in the State of Nevada to perform such work and shall be paid by Tenant. Any structural alterations desired by Tenant shall be subject to the obtaining of Landlord's consent, which shall not unreasonably be withheld. Landlord shall be notified at least ten (10) days prior to the commencement of any construction of any alterations so that Landlord may post appropriate notices of non-responsibility under Nevada law.

Any alterations to the premises which are required by reason of any present or future law, ordinance, rule, regulation or order of any governmental authority having jurisdiction over the premises shall be at the sole cost of Landlord. At the expiration or termination of the term of this Lease, all alterations to or upon the premises, except removable trade fixtures, equipment and personal property, shall be deemed to have attached to the feehold and to have become the property of Landlord.

Tenant at its expense may install in the premises such fixtures and equipment as Tenant may desire, and Tenant may from time to time remove, replace, alter or add to such fixtures and equipment. All fixtures and equipment installed by Tenant shall remain the property of Tenant and may be removed by Tenant at any time during or at the expiration of the term.

13. **Eminent Domain.** If there is any taking of or damage to all or any part of the premises or interest therein because of the exercise of the power of eminent domain, whether by condemnation proceedings or otherwise, or any transfer of any part of the premises or parking area or any interest therein made in avoidance of the exercise of the power of eminent domain (all of the foregoing being hereinafter referred to as "taking") prior to or during the term hereof, the rights and obligations of the Landlord and Tenant with respect to such taking shall be as follows:

A. If there is a taking of all of the premises, this Lease shall terminate as of the date of such taking.

B. If any portion of the premises shall be taken, or if so much of the parking area shall be taken (regardless of whether or not any part of the premises is taken) so that Tenant's use is no longer permissible under applicable zoning ordinances, then in that event Tenant shall be entitled to terminate this Lease.

If this Lease is terminated in accordance with the provisions of this Paragraph 13, such termination shall become effective as of the date physical possession of the particular portion is taken or immediate possession is ordered. The parties shall be released from all further liability hereunder. If this Lease is not terminated as provided in this Paragraph 13, Landlord shall restore the remainder of the premises so far as practicable to a complete unit of like quality, character, and condition as that which existed immediately prior to the taking.

If this Lease is not terminated as provided in this Paragraph 13, the annual fixed rent set forth in Paragraph 4A shall be reduced by the proportion which the number of square feet of usable floor area of the premises after the taking bears to the total usable floor area of the premises immediately prior to the taking.

The award or compensation in such proceedings, whether for a total or partial taking or for diminution in the value of the leasehold or for the fee, shall be apportioned pursuant to Nevada law.

14. Damage and Destruction. In the event the shell and structure of the building and/or parking area, or any part thereof, shall be damaged by any casualty, this Lease shall remain in full force and effect and Landlord shall repair such damage and restore such improvements to the same condition as existed prior to the casualty as rapidly as reasonably possible, provided that insurance proceeds from insurance carried by Landlord and/or Tenant are available for such repair and restoration.

In the event of any reconstruction by Landlord of the premises under this Paragraph 14, said reconstruction shall be in strict conformity with the plans and specifications and the building permit to be obtained with the City of Las Vegas. Landlord shall be responsible for repair, reconstruction or restoration of all of Landlord's Work required hereunder. Landlord shall not be responsible for the repair and restoration of Tenant's improvements or the replacement of Tenant's stock in trade, trade fixtures, furniture, furnishings and equipment.

Notwithstanding anything to the contrary contained in this Lease, in the event the premises is damaged by any casualty (i) not insured under the property insurance policy which Tenant is required to carry pursuant to this Lease, or (ii) during the last 12 months of the term, Tenant shall have the right to terminate this Lease by notice to Landlord given within thirty (30) days after the occurrence of the casualty.

In the event of damage or destruction to the premises, the fixed rent shall be abated proportionately with the degree to which Tenant's use of the premises is impaired, commencing from the date of destruction and continuing during the period of reconstruction and replacement or until the effective date of termination of this Lease, as the case may be.

Notwithstanding anything to the contrary contained in this Lease, in the event the building, or parking area, or any portion thereof, is damaged or destroyed and as a result thereof Tenant is denied



reasonable access to the premises, and is therefore unable to operate its business in the premises and in fact ceases such operation, then, whether or not the premises was damaged or destroyed, all rent shall abate from the date of the casualty until Tenant is again reasonably able to operate its business in the premises.

15. Default by Landlord. Landlord shall in no event be charged with default in the performance of any of its obligations hereunder unless and until Landlord shall have failed to perform such obligations within thirty (30) days (or such additional time as is reasonably required to correct any such defaults) after written notice by Tenant to Landlord properly specifying wherein Landlord has failed to perform any such obligation; provided, however, except as provided hereinafter in this Paragraph 15, Tenant shall not have the right to exercise any remedy provided for herein or at law unless and until Tenant shall have delivered a written notice to any lender holding a trust deed against the premises or portion thereof, whose name and address has been given to Tenant by written notice, specifying wherein Landlord has failed to correct or remedy such default, which such notice may not be delivered until after the expiration of the period set forth herein for Landlord to remedy such default and shall grant to the lender an additional equal period within which to cure such default.

Notwithstanding anything to the contrary contained in this Lease, if Landlord fails to make a repair or perform any maintenance required to be made or performed by it under the terms of this Lease, and such failure continues for a period of five (5) days after delivery of written notice to Landlord of the necessity for such repairs or maintenance or, in the case of an emergency, within such shorter period after delivery of such notice as shall be reasonable under the circumstances, Tenant may, without waiving any claim for damages or other remedy available to it, at any time thereafter make such repair or perform such maintenance for the account of Landlord. Any amount paid or any contractual liability incurred by Tenant in curing such failure shall be deemed paid or incurred for the account of Landlord, and Landlord agrees to hold Tenant harmless therefrom and reimburse Tenant upon demand therefor plus interest thereon at a rate equal to the lesser of (i) twelve percent (12%) per annum, or (ii) the maximum rate of interest permitted by law.

The liability of Landlord to Tenant for any default by Landlord under the terms of this Lease shall be limited to the lesser of (i) the interest of Landlord in the premises, or (ii) the interest Landlord would have in said premises if the same were encumbered by third party debt in an amount equal to eighty percent (80%) of the value of said premises, and Tenant agrees to look solely to such amount for recovery of any judgment from Landlord, it being intended that Landlord shall not be personally liable for any judgment or deficiency.

16. Tenant's Default. The following shall constitute a default under this Lease:

A. Tenant shall fail, neglect or refuse to pay any installment of fixed rent, additional rent or any other charge, including, without limitation, penalty charges, required to be paid by Tenant at the time and in the amount as herein provided, or pay any moneys agreed by it to be paid promptly



when and as the same shall become due and payable under the terms hereof and such default shall continue for a period of more than three (3) days after notice thereof in writing given to Tenant by Landlord.

B. Tenant shall fail, neglect or refuse to keep and perform any of the other covenants, conditions, or agreements required herein and such default shall continue for a period of more than fifteen (15) days after notice in writing given to Tenant by Landlord; provided, however, that if the cause for giving such notice involves the making of repairs or other matters reasonably requiring a longer period of time than the period of such notice, Tenant shall be deemed to have complied with such notice if Tenant has commenced to cure any such default and diligently proceeds to complete such cure.

C. Any attachment or levy of execution or similar seizure of the premises or Tenant's merchandise, fixtures or other property at the premises or any foreclosure, repossession, or sale under any chattel mortgage, security agreement or conditional sales contract covering Tenant's merchandise, fixtures or other property at the premises; or the filing of any petition by or (unless released or dismissed within 60 days) against Tenant under any chapter of the Bankruptcy Code, or the adjudication of Tenant as a bankrupt or insolvent; or the appointment of a receiver or trustee to take possession of all or substantially all of the assets of Tenant or a general assignment by Tenant for the benefit of creditors; or any other action taken or suffered by Tenant under any state or federal insolvency or bankruptcy act and the continuation thereof for more than sixty (60) days,

D. Tenant shall refuse to take possession of the premises or shall abandon the premises once Tenant has taken possession.

In the event of an act of default by Tenant, Landlord may, at its option: (1) terminate Tenant's right to possession of the premises because of such breach and recover from Tenant all damages allowed under laws of the State of Nevada, including, without limitation, the worth at the time of the award of the amount by which the unpaid rent for the balance of the term after the time of award exceeds the amount of such rental loss that Tenant proves could be reasonably avoided; or (2) not terminate Tenant's right to possession because of such breach, but continue this Lease in full force and effect; and in that event Landlord may enforce all rights and remedies under this Lease, including the right to recover the rent and all other charges due hereunder as such rent and other charges become due; or (3) declare a forfeiture of the Lease and terminate all of Tenant's rights in accordance with such forfeiture.

In the event of any reentry, Landlord may remove all persons from the premises and all property and any signs located in or about the premises and place such property in storage in a public warehouse at the cost and risk of Tenant.

Except in the case of Landlord's willful misconduct, Tenant hereby waives all claims or demands for damages that may be caused by Landlord in reentering and taking possession of the premises as hereinabove provided and all claims or demand for damages which may result from the destruction of



or injury to the premises and all claims or demands for damage or loss of property belonging to Tenant or to any other person or firm that may be in or about the premises at the time of such reentry.

Nothing contained in this Lease shall limit Landlord to the remedies set forth in this Paragraph, and upon Tenant's default Landlord shall be entitled to exercise any right or remedy then provided by law; including, but without limitation, the right to obtain injunctive relief and the right to recover all damages caused by Tenant's default in the performance of any of its obligations under this Lease.

Neither this Lease nor any interest herein nor any estate hereby shall pass by operation of law under any State or Federal insolvency or bankruptcy act to any trustee, receiver, assignee for the benefit of creditors or any other person whatsoever without the prior written consent of Landlord.

If Tenant shall fail to pay within three (3) days after receipt of notice that the same is past due and payable, any rent or additional rent or amounts or charges under this Lease is due and payable, such amounts shall bear interest at the maximum lawful rate (not to exceed 12% per annum) from the date due to the date of payment. In addition to such interest, Tenant acknowledges that the late payment by Tenant of any such amount will cause Landlord to incur certain costs and expenses not contemplated under this Lease, the exact amount of which costs being extremely difficult or impractical to fix. Such costs and expenses will include, without limitation, administrative and collection costs, and processing and accounting expenses. Therefore, if any such payment is not received by Landlord within three (3) days after receipt of notice that the same is past due, Tenant shall immediately pay to Landlord a late charge equal to five percent (5%) of the overdue amount. Landlord and Tenant agree that this late charge represents a reasonable sum considering all of the circumstances existing on the date of this Lease, including the relationship of the sum to the loss to Landlord that could reasonably be anticipated by such non-payment by Tenant, and the anticipation that proof of actual damages would be costly or inconvenient to determine. Acceptance of such late charge shall not constitute a waiver of Tenant's default with respect to such non-payment by Tenant nor shall it prevent Landlord from exercising all other rights and remedies available to Landlord under this Lease.

If the Tenant becomes a debtor under Chapter 7 of the United States Bankruptcy Code (the "*Bankruptcy Code*"), or in the event that a petition for reorganization or adjustment of debts is filed concerning the Tenant under Chapter 11 or Chapter 13 of the Bankruptcy Code, or a proceeding filed under Chapter 7 is transferred to Chapter 11 or 13, the "*Trustee*" or the Tenant, as "*Debtor-in-Possession*," shall be deemed to have rejected this Lease. No election by the Trustee or Debtor-in-Possession to assume this Lease shall be effective unless each of the following conditions, which Landlord and Tenant hereby acknowledge to be commercially reasonable in the context of a bankruptcy proceeding, has been satisfied, and the Landlord has so acknowledged in writing: (i) the Trustee or Debtor-in-Possession has cured, or has provided the Landlord "*adequate assurance*" (as hereinafter defined) that from the date of such assumption the Trustee or Debtor-In-Possession will promptly cure, all monetary and non-monetary defaults under the Lease; (ii) the Trustee or Debtor-in-Possession has compensated, or has provided to the Landlord adequate assurance that within ten (10) days of the date



of assumption the Landlord will be compensated, for any pecuniary loss incurred by the Landlord arising from default of the Tenant, the Trustee, or the Debtor-in-Possession as recited in the Landlord's written statement of pecuniary loss sent to the Trustee or Debtor-in-Possession; and (iii) the Trustee or Debtor-in-Possession has provided the Landlord with adequate assurance of future performance of each of the Tenant's, the Trustee's, or the Debtor-in-Possession's obligations under this Lease; provided, however, that: (x) the Trustee or Debtor-in-Possession shall also deposit with the Landlord, as security for the timely payment of rent and other sums due hereunder, an amount equal to three months Base Rent, Additional Rent, and other monetary charges accruing under this Lease; and (y) the obligations imposed upon the Trustee or Debtor-in-Possession shall continue with respect to the Tenant or any assignee of this Lease after the completion of the bankruptcy proceedings.

*Adequate Assurance.* For purposes of this Lease, Landlord and Tenant acknowledge that, in the context of the bankruptcy proceedings of the Tenant, at a minimum, "adequate assurance" shall mean: (i) the Trustee or Debtor-in-Possession will continue to have sufficient unencumbered assets after the payment of all secured obligations and administrative expenses to assure the Landlord that the Trustee or Debtor-in-Possession will have sufficient funds to fulfill all of the obligations of Tenant under this Lease; or (ii) the Bankruptcy Court shall have entered an order segregating sufficient cash payable to the Landlord, and the Trustee or Debtor-in-Possession shall have granted to the Landlord a valid and perfected first lien and security interest or mortgage in property of the Tenant, the Trustee, or the Debtor-in-Possession, acceptable as to value and kind to the Landlord, in order to secure to the Landlord the obligation of the Tenant, Trustee, or Debtor-in-Possession to cure the monetary or non-monetary defaults under the Lease within the time period set forth above.

*Lease Assignments in Bankruptcy Proceedings.* The following conditions shall apply to any assignments of this Lease in bankruptcy proceedings if the Trustee or Debtor-in-Possession has assumed this Lease and elects to assign the Lease to any other person, such interest or estate of Tenant in this Lease may be so assigned only if the Landlord has acknowledged in writing that the intended assignee can provide to the Landlord "adequate assurance of future performance" (as herein defined) of all of the terms, covenants and conditions of this Lease to be performed by the Tenant. For the purposes of this provision, Landlord and Tenant acknowledge that, in the context of a bankruptcy proceeding, at a minimum, "adequate assurance of future performance" shall mean that each of the following conditions has been satisfied, and the Landlord has so acknowledged in writing: (i) the proposed assignee has submitted a current financial statement audited by a Certified Public Accountant which shows the net worth and working capital and amounts determined by Landlord to be sufficient to assure the future performance by such assignee of all of Tenant's obligations under this Lease; (ii) the proposed assignee, if requested by the Landlord, has obtained guarantys in form and substance satisfactory to the Landlord from one or more persons who satisfy the Landlord's standards of creditworthiness; and (iii) the Landlord has obtained all consents or waivers from any third party required under any lease, mortgage, financing arrangement, or other agreement by which the Landlord is bound, in order to permit the Landlord to consent to such assignment.



**17. Indemnification, Release and Liens.** Except as otherwise provided in this Lease, Tenant agrees that Landlord shall not be liable, responsible, or in any way accountable, to Tenant, Tenant's agents, employees, servants, customers or invitees, or to any person whomever, for any loss, theft or destruction of or damage (including, but not limited to, any damage caused by rain, storm or other water damage) to any goods, wares, merchandise, fixtures or other property stored, kept, maintained, on or about the premises, or in, on or about the facilities, the use of which Tenant may have in conjunction with this Lease, nor for injury to or death of any person or persons who may at any time be using, occupying or visiting the premises.

Except to the extent contributed to by the gross negligence or willful misconduct of Landlord, its agents, employees or contractors, Tenant shall indemnify, defend and hold harmless Landlord, its agents and employees from and against any and all damages, claims, losses, liabilities, costs and expenses (including, without limitation, reasonable attorneys' fees), for damage to or loss of property (including Tenant's property) or injury to or death of persons (including Tenant, its agents, employees, visitors, or invitees) directly or indirectly resulting from anything occurring from any cause on or about the premises, in connection with the maintenance or operation of Tenant's business, or Tenant's occupation or use of the premises. Tenant shall discharge any judgment or compromise rendered against or suffered by Landlord as a result of anything indemnified against hereunder and shall reimburse Landlord for any and all costs, fees or expenses incurred or paid by Landlord (including, without limitation, reasonable attorneys' fees) in connection with the defense of any such action or claim.

Except to the extent contributed to by the gross negligence or willful misconduct of Tenant, its agents, employees or contractors, Landlord shall indemnify, defend and hold Tenant harmless from and against any and all damages, claims, losses, liabilities, costs and expenses (including, without limitation, reasonable attorneys' fees) due to claims of third persons arising from or in connection with Landlord's ownership, management, repair, maintenance or reconstruction of the building or any part thereof, or any act, omission, fault or negligence of Landlord or Landlord's agents, contractors or employees or any failure on Landlord's part or the part of Landlord's agents, contractors or employees to comply with any of the terms, covenants and conditions contained in this Lease.

To the extent arising out of work or materials provided by or on behalf of Tenant, Tenant shall keep the premises and all of the right, title and interest of Tenant and Landlord therein free and clear of all liens or claims which may ripen into such a lien or encumbrance, and in the event Tenant fails to do so, Landlord may pay such lien or encumbrance or claim, and on or before the tenth (10th) day of the month following the month during which such payment is made, Tenant shall pay to Landlord such sums so paid, plus such reasonable costs and attorneys' fees as may have been incurred by Landlord; provided, however, that in the event Tenant in good faith disputes such lien or encumbrance and with reasonable promptness furnishes an indemnity bond or such undertaking in an amount sufficient either to procure the release of such lien or encumbrance or to indemnify against the principal amounts thereof, together with such costs or attorneys' fees as may be covered by said lien or encumbrance, then



the furnishing of such bond or undertaking shall be deemed due compliance with the foregoing provision.

**18. ~~Non-Disturbance, Subordination and Financing.~~** This Lease is and shall be junior to the financing to be obtained by Landlord prior to the performance of Landlord's Work hereunder (the "Initial Deed of Trust"). This Lease is and shall be prior to any subsequent deed of trust affecting all or any part of the premises. If, however, the holder of any such subsequent deed of trust requires that this Lease be subordinated to such deed of trust, Tenant agrees to subordinate this Lease to that deed of trust if Landlord first obtains from such holder a written nondisturbance agreement in form and substance similar to Exhibit "E-1" attached hereto. In no event shall Tenant's obligations be increased or Tenant's rights decreased by such nondisturbance agreement. Such nondisturbance agreement shall be recorded in the office of the county recorder of the county in which the premises are located. The terms "Initial Deed of Trust" and "deed of trust" as used herein include mortgages, deeds of trust, other monetary liens or encumbrances, all modifications, extensions, renewals and replacements thereof, given as collateral security for any obligation affecting the premises.

Tenant shall receive from the lender under the Initial Deed of Trust, and from the Ground Lessor under the Ground Lease, a Nondisturbance and attornment agreement substantially in the form attached hereto as Exhibit "E-1" and "E-2", respectively, within forty-five (45) days after the date of this Lease.

Upon payment by Tenant of all of the rents herein provided, and upon the observation and performance of all of the covenants, terms and conditions on Tenant's part to be observed and performed, Tenant shall quietly hold and enjoy the premises for the term hereby leased without hindrance or interruption by Landlord or any other person or persons lawfully or equitably claiming by, through or under Landlord, subject nevertheless to the terms and conditions of this Lease.

At any time and from time to time, upon request in writing from either party, the other party agrees to execute, acknowledge and deliver to the requesting party a statement in writing certifying that this Lease is unmodified and in full force and effect (or if there have been modifications that the same is in full force and effect as modified and stating the modifications), the dates to which fixed rent, and other charges have been paid, the expiration date of the term and any other matters regarding this Lease as reasonably requested. It is understood and agreed that any such statement may be relied upon by any prospective purchaser of the leasehold or the mortgagee, beneficiary or grantee of any security or interest, or any assignee of any thereof, under any mortgage or deed of trust now or hereafter made covering any leasehold interest in the premises or the real property covered by this Lease, or any assignee, subtenant or successor of Tenant.

In the event any proceedings are brought for foreclosure, or in the event of the exercise of the power of sale under any mortgage or deed of trust made by the Landlord covering the premises or should the Lease in which Landlord is the tenant be terminated, the Tenant shall attorn to the purchaser

or landlord under said Lease upon any such foreclosure, sale or lease termination and recognize such purchaser or landlord as the Landlord under this Lease and the purchaser or lessor shall acquire and accept the premises subject to this Lease.

Landlord and Tenant shall each execute and deliver to the other the appropriate documents required hereunder not later than twenty (20) days from receipt of written request therefor.

If, during the term of this Lease, Landlord sells its interest in the premises, or this Lease, or all or any portion of the building, then all rights and obligations of Tenant hereunder shall remain in full force and effect as though there had been no such sale or transfer. Upon such transfer and conveyance, Landlord shall be unconditionally released of all obligations of Landlord thereafter accruing hereunder from the date of such sale or transfer.

This Lease shall not be recorded without the prior written consent of Landlord; provided, however, if either party so requests, Landlord and Tenant agree to execute and deliver a short form or memorandum of this Lease for recordation.

19. Surrender of Premises. At the expiration of the term of this Lease, Tenant shall surrender to Landlord the premises in good order and condition, reasonable wear and tear, Landlord's obligations and casualty damage excepted, and shall surrender all keys for the premises to Landlord at the place then fixed for the payment of rent and shall inform Landlord of all combinations on locks, safes and vaults, if any, in the premises. No act or conduct of Landlord, except a written acknowledgment of acceptance of surrender signed by Landlord, shall be deemed to be or constitute an acceptance of the surrender of the premises by Tenant prior to the expiration of the term of this Lease.

If, prior to the termination of this Lease or within fifteen (15) days thereafter, Landlord elects by written notice to Tenant, Tenant shall promptly remove the trade fixtures, signs and personal property which were placed in the premises by Tenant and which are designated in said notice and shall repair any damage occasioned by such removal; and in default thereof Landlord may effect said removals and repairs at Tenant's expense. The covenants of Tenant contained herein shall survive the expiration or termination of the term.

20. Construction of Premises; Cooperation. At no cost to Tenant, Landlord shall assist and cooperate with Tenant in Tenant's efforts to obtain approval of Tenant's plans, if any, by all appropriate governmental agencies. In the event that prior to or during the construction of any work or improvements prior to the commencement of rent, any asbestos or asbestos containing material (collectively, "ACM") is found in the premises, the commencement of rent shall be extended by the number of days Tenant's Work is delayed solely by virtue of any work in connection with the removal of such ACM.

21. Notices. Whenever under this Lease a provision is made for any notice, request, demand



or other communication (collectively, "notice") to a party it shall be in writing delivered personally, by certified mail, return receipt requested, with postage prepaid, or by recognized overnight courier service providing a receipt for delivery, addressed to Tenant or to Landlord at the address on page (iii) of this Lease. Either party may by like notice at any time and from time to time designate a different address to which or a different person to whom or in care of whom notices shall be sent. Notices which are mailed or sent by overnight courier shall be deemed delivered upon actual receipt or attempted delivery as shown in the return receipt.

22. **Attorneys' Fees.** In case suit shall be brought for any breach of this Lease, the prevailing party shall be entitled to reasonable attorneys' fees, at trial or on appeal, which shall be fixed by the Court or in any compromise or settlement. Such attorneys' fees shall be deemed to have accrued on the commencement of such action and shall be paid whether or not such action is prosecuted to judgment. If either party shall employ the services of any attorney(s) by reason of any default or failure of timely performance by the other party and suit is not brought thereon, the defaulting party shall pay to the other party all attorneys fees so incurred.

23. **Assignment and Subletting.** Tenant shall be permitted to assign this Lease, or any interest therein, and to sublet the premises or any part thereof, and be allowed to permit any other person to occupy or use the premises, or any portion thereof, without first obtaining the consent of Landlord, for any of the uses permitted in this Lease. No assignment or sublease shall release the Tenant from liability for the continued performance of the terms and provisions on the part of Tenant to be kept and performed, unless Landlord specifically releases the Tenant from said liability. No other assignment or subletting shall be permitted without Landlord's consent, which shall not unreasonably be withheld.

In the event of default by any assignee of Tenant or any successor of Tenant in the performance of any of the terms hereof, Landlord may proceed directly against Tenant without the necessity of exhausting remedies against such assignee or successor.

24. **Access.** Upon 24 hours prior written notice to Tenant, Landlord and its agents shall have reasonable access to the premises during all reasonable hours for the purpose of examining the same and to ascertain if Tenant is in compliance with the terms of this Lease, to exhibit the same to prospective purchasers or tenants and to post notices of nonresponsibility in reasonable locations and at reasonable times. During any entry into the premises Landlord shall use its best efforts to minimize interference with Tenant's business operations.

25. **Holdover.** In the event the Tenant shall hold over the premises after the expiration of the term hereof with the consent of the Landlord either express or implied, such holding over shall be construed to be only a tenancy from month-to-month, subject to all the covenants, conditions and obligations hereof and the Tenant hereby agrees to pay the Landlord the same rentals, plus ten percent (10%), provided for by this Lease for such additional times as Tenant shall hold such property.

26. Insolvency of Tenant. Tenant agrees that in the event all or substantially all of its assets be placed in the hands of a receiver or trustee, and in the event such receivership or trusteeship continues for a period of thirty (30) days, or should Tenant make an assignment for the benefit of creditors, or be adjudicated a bankrupt, or should Tenant institute any proceedings under any state or federal bankruptcy act wherein Tenant seeks to be adjudicated a bankrupt or seeks to be discharged of its debts, or should any voluntary proceeding be filed against such Tenant under such bankruptcy laws and Tenant consents thereto or acquiesces therein by pleading or default, then this Lease or any interest in and to the premises shall not become an asset in any of such proceedings and, in any of such events and in addition to any and all rights or remedies of Landlord hereunder or as provided by law, it shall be lawful for Landlord at its option to declare the term hereof ended and to reenter the premises and take possession thereof and remove all persons therefrom and Tenant shall have no further claim therein or hereunder.

27. Surrender of Lease. The voluntary or other surrender of this Lease by Tenant, or a mutual cancellation thereof, shall not work a merger, and shall, at the option of Landlord, terminate all or any existing subleases or subtenancies, or may, at the option of Landlord, operate as an assignment to it of any or all of such subleases or subtenancies.

28. Sale of Premises by Landlord. In the event of any sale of the premises by Landlord, Landlord shall be and is hereby entirely freed and relieved of all liability under any and all of its covenants and obligations contained in or derived from this Lease arising out of any act, occurrence or omission occurring after the consummation of such sale; and the purchaser, at such sale or any subsequent sale of the premises shall be deemed, without any further agreement between the parties or their successors in interest or between the parties and any such purchaser, to have assumed and agreed to carry out any and all of the covenants and obligations of the Landlord under this Lease.

29. Signs. Tenant may install and maintain upon the premises, including the front, sides and rear exterior parapet walls, such building identification signs advertising the business conducted on the premises by Tenant as are permitted by applicable law. All building signs installed by Tenant shall comply with all applicable laws, rules and ordinances of state or local governmental authorities, shall remain the property of Tenant, and may be removed by Tenant at the termination of this Lease.

30. Miscellaneous.

A. The laws of the State of Nevada shall govern the validity, construction, performance and enforcement of this Lease.

B. The unenforceability or invalidity of any one or more provisions hereof shall not render any other provisions herein contained unenforceable or invalid.

C. As used in this Lease and whenever required by the context thereof, each number,



both singular or plural, shall include all numbers, and each gender shall include all genders. Landlord and Tenant as used in this Lease or in any other instrument referred to in or made a part of this Lease shall likewise include both the singular and the plural, a corporation, co-partnership, individual or person acting in any fiduciary capacity as executor, administrator, trustee, or in any other representative capacity. All covenants herein contained shall be joint and several.

D. The paragraph titles herein are for convenience only and do not define, limit or construe the contents of such paragraphs.

E. One or more waivers of any covenant, term or condition of this Lease by either party shall not be construed by the other party as a waiver of a subsequent breach of the same or any other covenant, term or condition. The consent or approval of either party to or of any act by the other party of a nature requiring consent or approval shall not be deemed to waive or render unnecessary consent to or approval of any subsequent act.

F. All of the terms hereof shall apply to, run in favor of and shall be binding upon and inure to the benefit of, as the case may require, the parties hereto, and also their respective heirs, executors, administrators, personal representatives and assigns and successors in interest.

G. IT IS UNDERSTOOD THAT THERE ARE NO ORAL AGREEMENTS BETWEEN THE PARTIES AFFECTING THIS LEASE AND THIS LEASE SUPERSEDES AND CANCELS ANY AND ALL PREVIOUS NEGOTIATIONS, ARRANGEMENTS, BROCHURES, AGREEMENTS, REPRESENTATIONS AND UNDERSTANDINGS, IF ANY, BETWEEN THE PARTIES HERETO OR DISPLAYED BY LANDLORD TO TENANT WITH RESPECT TO THE SUBJECT MATTER THEREOF AND NONE SHALL BE USED TO INTERPRET OR CONSTRUCE THIS LEASE. FURTHERMORE, THE PARTIES EXPRESSLY AGREE THAT THIS LEASE AND THE AGREEMENTS CONTAINED HEREIN SHALL ONLY BE AMENDED OR MODIFIED BY AN AGREEMENT IN WRITING SIGNED BY BOTH LANDLORD AND TENANT AND ABSENT ANY SUCH WRITTEN AGREEMENT THIS LEASE ALONE SHALL CONSTITUTE THE ENTIRE AGREEMENT (PAST, PRESENT AND FUTURE) BETWEEN THE PARTIES.

H. Each individual signing on behalf of a party hereto represents and warrants that he or she is authorized by the Board of Directors, managing partner or other appropriate body or individual, as the case may be, to execute this Lease on behalf of such party.

I. Any prevention, delay or stoppage due to strikes, lockouts, labor disputes, acts of God, inability to obtain labor or materials or reasonable substitutes therefor, governmental restrictions, governmental regulations, governmental controls, judicial orders, enemy or hostile governmental action, civil commotion, fire or other casualty, and other causes beyond the reasonable control of the party obligated to perform, shall excuse the performance by such party for a period equal to any such

prevention, delay or stoppage. In the event Tenant encounters any of the foregoing prior to the commencement date, the commencement date shall be postponed by a period equal to the length of any such prevention, delay or stoppage, but in no event shall the commencement date be postponed to a date later than the date Tenant initially opens the premises for business to the public.

J. Except as expressly otherwise herein provided, time is of the essence of this Lease and all obligations of the parties hereto.

K. Landlord and Tenant hereby waive trial by jury in any action, proceeding, or counterclaim brought by either of the parties to this Lease against the other on any matters whatsoever arising out of or in any way connected with this Lease, the relationship of Landlord and Tenant, Tenant's use or occupancy of the premises, or any other claims (except claims for personal injury or property damage), and any emergency or other statutory remedy.

LANDLORD:

TENANT:

V.A. CLINIC ASSOCIATES,  
a Nevada limited Partnership

UNIVERSITY OF NEVADA SCHOOL OF MEDICINE  
MULTI-SPECIALTY GROUP PRACTICE SOUTH, INC.,  
a Nevada corporation

  
Mark L. Fine, General Partner

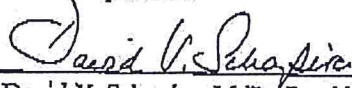
  
By: David V. Schapira, M.D., President

APPROVED:  
University of Nevada School of Medicine  
Integrated Clinical Services, Inc.,  
a Nevada corporation

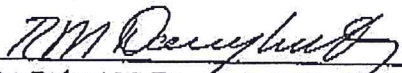
  
By: Robert M. Daugherty M.D., Ph.D., President



Leases. In such event, all of Tenant's interest under the Sub-Leases shall be deemed automatically assigned, transferred and conveyed to Landlord. Landlord shall thereafter be bound on the Sub-Leases to the same extent Tenant was so bound and shall have all the rights that Tenant has under the Sub-Leases, including the right to collect rents from Sub-Tenants under the Sub-Leases and the right to terminate the Sub-Leases upon default by Sub-Tenants.

4. *Successors and Assigns.* This Agreement shall be binding on and shall inure to the benefit of the parties hereto and their successors and assigns.

IN WITNESS WHEREOF, the parties hereto have executed this Agreement as of the day and year first above written.

**LANDLORD:**

**SUB-TENANT:**

**UNIVERSITY OF NEVADA SCHOOL OF  
MEDICINE MULTI-SPECIALTY GROUP  
PRACTICE SOUTH, INC.**

By: \_\_\_\_\_  
SANDRA BUSHROE

By: \_\_\_\_\_  
LINDA MAY ZOELLER

By: \_\_\_\_\_  
Its: \_\_\_\_\_

**TENANT:**

**APPROVED:**

**V.A. CLINIC ASSOCIATES,  
a Nevada limited partnership**

**University of Nevada School of Medicine  
Integrated Clinical Services, Inc.,  
a Nevada corporation**

By: \_\_\_\_\_

By: \_\_\_\_\_  
Robert M. Daugherty, M.D., Ph.D., President



## VA CLINIC ASSOCIATES

## LEASE SUMMARY

1. Landlord: VA Clinic Associates
2. Tenant: University of Nevada School of Medicine  
Multi-Specialty Group Practice South, Inc.
3. Guarantor: N/A
4. Premises: 1703 W. Charleston Blvd., Las Vegas, NV 89102
5. Rentable Square Feet: 44,824
6. Usable Square Feet: 38,377
7. Commencement Date: 90 days after delivery of space substantially  
complete, but not later than July 15, 1998
8. Expiration Date: December 1, 2005
9. Term: Seven (7) years
10. Rent Commencement Date: August 1, 1998
11. Initial Base Rent (Annual): \$660,000
12. Initial Base Rent: \$1.43 per net rentable square feet or \$55,000 per  
month
13. Increase in Base rent: None during initial 7 year lease
14. Security Deposit: None
15. Tenant's Pro Rata Share  
of the Building: Entire building
16. Broker: Mark Fine & Associates
17. Option to Renew: Two (2) five year options



**EXHIBIT A**

**LEGAL DESCRIPTION OF LAND**

Lot 3 of Ellis Estates, as shown by map thereof on file in Book 2 of Plats, Page 61, in the Office of the County Recorder of Clark County, Nevada, excepting therefrom the South 87 feet thereof.

**LEGAL DESCRIPTION OF APPROXIMATE 1/2 ACRE GROUND LEASED PARCEL**

Parcel No 3-66 202, further known as 1119 Shadow Lane, as shown on Tax Assessor Plat of the Tax Assessor, Las Vegas, Nevada.





# EXHIBIT 'B'

ATTACHED TO LEASE DATED JAN. 20, 1998

BY AND BETWEEN VA CLINIC ASSOCIATES (LAND LORD) AND  
UNIVERSITY OF NEVADA SCHOOL OF MEDICINE  
MULTI-SPECIALTY GROUP PRACTICE SOUTH, INC. (TENANT)

1 SITE PLAN

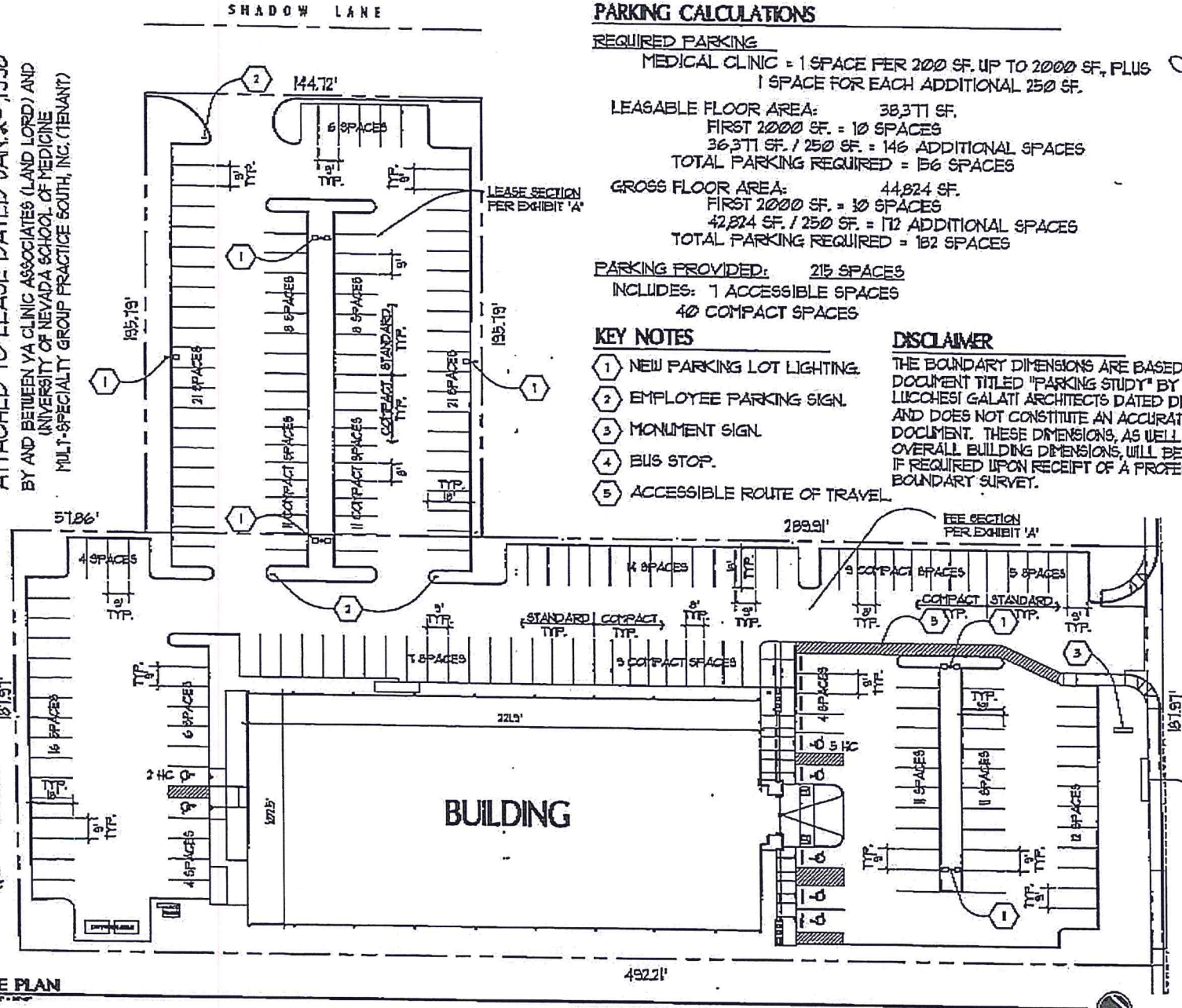

## PARKING CALCULATIONS

### REQUIRED PARKING

MEDICAL CLINIC = 1 SPACE PER 200 SF. UP TO 2000 SF., PLUS  
1 SPACE FOR EACH ADDITIONAL 250 SF.

LEASABLE FLOOR AREA: 38,371 SF.  
FIRST 2000 SF. = 10 SPACES  
36,371 SF. / 250 SF. = 146 ADDITIONAL SPACES  
TOTAL PARKING REQUIRED = 156 SPACES

GROSS FLOOR AREA: 44,824 SF.  
FIRST 2000 SF. = 10 SPACES  
42,824 SF. / 250 SF. = 172 ADDITIONAL SPACES  
TOTAL PARKING REQUIRED = 182 SPACES

PARKING PROVIDED: 215 SPACES

INCLUDES: 7 ACCESSIBLE SPACES  
40 COMPACT SPACES

### KEY NOTES

- 1 NEW PARKING LOT LIGHTING.
- 2 EMPLOYEE PARKING SIGN.
- 3 MONUMENT SIGN.
- 4 BUS STOP.
- 5 ACCESSIBLE ROUTE OF TRAVEL.

### DISCLAIMER

THE BOUNDARY DIMENSIONS ARE BASED ON A DOCUMENT TITLED "PARKING STUDY" BY LICCHESI GALATI ARCHITECTS DATED DEC. 5, 1996 AND DOES NOT CONSTITUTE AN ACCURATE SURVEYED DOCUMENT. THESE DIMENSIONS, AS WELL AS THE OVERALL BUILDING DIMENSIONS, WILL BE MODIFIED IF REQUIRED UPON RECEIPT OF A PROFESSIONAL BOUNDARY SURVEY.

PLEASE INITIAL

CHARLESTON BLVD.

**EXHIBIT C**  
**PROVISIONS REGARDING**

**LANDLORD'S WORK AND TENANT'S WORK AND**  
**LANDLORD'S CONSTRUCTION ALLOWANCE**

A. **Landlord's Work.** Within thirty days after the date of this Lease, but in no event later than January 15, 1998, Landlord shall deliver to Tenant a complete and final set of Landlord approved architectural and engineering plans and outline specifications respecting the construction work necessary to bring the premises to Class "A" office building standards within the County of Clark. Said plans shall fully describe the following works of improvement, including without limitation, the two lane driveway on Shadow Lane which has been approved by the City of Las Vegas, the building shell and facade, roof, HVAC and elevator systems, building entrances, common passageways, restrooms, common waiting areas, building mechanical systems, the manner in which utility connections shall be integrated into, and provide for connection to, the building, asbestos removal, landscaping, parking layout, including all striping, berms, poles, signs and any other improvements necessary to bring the premises to the Class "A" standard ("Landlord's Plans and Specifications").

Landlord's Plans and Specifications shall be prepared in compliance with all city, county, state and federal ordinances, rules and regulations related thereto and stamped by Landlord's architects and engineers fully qualified and licensed to prepare the drawings required herein, which shall be fully detailed and dimensioned and prepared at Landlord's expense. Within ten (10) working days after receipt of Landlord's Plans and Specifications, Tenant shall deliver to Landlord any and all changes which Tenant deems necessary or desirable. Landlord shall have ten (10) working days thereafter to resubmit Landlord's Plans and Specifications to Tenant for approval. Thereafter, Tenant shall have five (5) working days to deliver to Landlord its approval of Landlord's Plans and Specifications and/or any required further modifications.

On or before January 15, 1998, Landlord will apply for appropriate permits and commence and thereafter complete at its expense, the construction work necessary to comply with the final Landlord's Plans and Specifications approval by Tenant ("Landlord's Work"). Landlord agrees to complete Landlord's Work no later than May 1, 1998.

Landlord's Work shall include, but shall not be limited to, the following:

- (a) Exterior facade including new entrances and (6) new windows at north (front) entrance.
- (b) New windows on 1st floor east and south side (Plastic Surgery) and modification to rear





entrance to convert "Receiving" to "Plastic Surgery" in accordance with agreed upon drawing dated December 31, 1997.

- (c) Paint entire exterior of building.
- (d) Provide new exterior landscaping and lighting.
- (e) New interior lobby and atrium.
- (f) Modify north stairwell by rotating 90 degrees.
- (g) Upgrade elevator cabs.
- (h) Monumentation for signage.
- (i) Replace or restore roof in accordance to recommendations provided by a certified and licensed roofing contractor or consultant as agreed upon by Tenant.
- (j) Remove all hazardous materials (including asbestos) in all areas and the existing Halon system.
- (k) Replace or repair or add all equipment necessary to provide adequate and dependable electrical service, including transformers, main switchgear and panelboards as agreed upon by Tenant to provide a "Class A" building.
- (l) Replace or repair or add all equipment necessary to provide adequate and dependable HVAC service, and related electrical equipment as agreed upon by Tenant to provide a so-called "Class A" building. Automatic temperature control equipment for building to be provided and installed by Tenant.
- (m) Replace, repair or add all equipment necessary to provide adequate and dependable plumbing services to the building, including without limitation, hot and cold domestic water, sanitary sewage, fire sprinklers and lawn irrigation as agreed upon by Tenant to provide a "Class A" building.
- (n) All work shown on the following drawings or required by all applicable codes, including all drawings submitted for Landlord's work and signed, dated and approved by the facilities manager for Tenant:

- (1) Architectural;
- (2) Landscaping;
- (3) Mechanical;
- (4) Electrical;
- (5) Plumbing; and
- (6) Structural.

From the commencement until the completion of Landlord's Work, Landlord shall obtain and maintain, at Landlord's expense, public liability and worker's compensation insurance in an amount sufficient to fully protect Tenant and Landlord from and against liability for death or injury to persons and for damage to property caused by or arising from the performance of Landlord's Work. Tenant shall obtain and maintain, at Tenant's expense, the same insurance during all periods in which Tenant is constructing Tenant's Work as provided in this Exhibit C.

B. Tenant's Work. On or about May 1, 1998, or such earlier date as Landlord's Work shall





either (a) have been completed and Landlord shall deliver the premises to Tenant, or (b) Landlord and Tenant agree that Tenant's contractor may commence Tenant's Work during the performance of Landlord's Work, Tenant will commence and thereafter complete Tenant's Work. Tenant's Work shall be in accordance with Tenant's plans and specifications, to be prepared at the expense and discretion of the Tenant and not subject to Landlord's approval as to quality, design, cost or for any other reason whatsoever, but subject to (i) the obtaining of all required permits for Tenant's Work, (ii) Tenant's Work being performed by contractors licensed to perform such work; and (iii) such reasonable reviews and approvals as may be required by Landlord's lender, consistent with lending and construction control practices in Clark County, Nevada.

Tenant's Work shall include, without limitation, the following:

- (a) Architectural space planning;
- (b) Signage;
- (c) Phones and data lines;
- (d) All improvements within the Premises, except major electrical and mechanical upgrades, structural revisions, revisions to the building envelope (windows, exterior doors, roof penetrations, roof, etc.), which shall be at Landlord's sole cost and expense.

Tenant shall deliver an original Certificate of Occupancy, if applicable, or final inspection release to Landlord after completion of Tenant's Work or Tenant's opening for business. Tenant shall obtain and record a Notice of Completion promptly following completion of Tenant's Work and shall promptly forward a certified copy thereof to Landlord.

C. Landlord's Construction Allowance. Within 45 days after the date of this Lease, Landlord shall deliver to Tenant documentation sufficient to assure Tenant that the sum of One Million Eight Hundred Thousand Dollars (\$1,800,000), has been allocated by Landlord or Landlord's lender for the use of Tenant to pay construction costs for Tenant's Work and other costs in connection with Tenant's use of the premises. It is understood and agreed by both Landlord and Tenant that the entire \$1,800,000 will be fully drawn from this fund by Tenant during the construction of Tenant's Work, but in no event later than December 1, 1998. The Landlord's Construction Allowance shall be held and distributed in accordance with a standard construction control account, with appropriate progress payments, verification procedures and retentions as are customary in Clark County, Nevada. A portion of the Landlord's Construction Allowance may be provided by Landlord in the form of a donation to the University of Nevada School of Medicine, in such form as may qualify for a charitable donation under applicable tax laws and regulations.

D. Landlord shall be responsible for any alterations, modifications or improvements as part of Landlord's Work which are required under Title III of the Americans With Disabilities Act ("ADA").

E. Tenant shall be responsible for any alterations, modifications or improvements as part of



Tenant's Work which are required under Title III of the ADA. In addition, once Tenant's Work has been completed, Tenant, at Tenant's sole cost and expense, shall be responsible for any alterations, modifications or improvements to the premises, and the acquisitions of any auxiliary aids, required under the ADA, including all alterations, modifications, or improvements required: (i) as a result of Tenant (or any subtenant, assignee, or concessionaire) being a "Public Accommodation" (as defined in the ADA); (ii) as a result of the premises being a "Commercial Facility" (as defined in the ADA); (iii) as a result of any leasehold improvements made to the premises by, or on behalf of, Tenant or any subtenant, assignee, or concessionaire (whether or not Landlord's consent to such leasehold improvements was obtained or required); or (iv) as a result of the employment by Tenant (or any subtenant, assignee, or concessionaire) of any individual with a disability.

F. Credit Against Landlord's Contribution Allowance. Landlord and Tenant have agreed that Landlord's Contribution Allowance includes the sum of \$248,000 for HVAC/automatic air temperature controls and new rooftop HVAC units (collectively, the "HVAC") which Tenant will perform as part of Tenant's Work. If, at the completion of Tenant's Work, Tenant has expended less than \$248,000 for the HVAC, Tenant agrees to provide Landlord with a credit (the "Credit") against Landlord's Contribution Allowance equal to the difference between \$248,000 and the amount actually expended for the HVAC; provided, however, the Credit shall not, in any event, be more than \$88,000. For example, if Tenant expends \$240,000 for the HVAC, the Credit shall be \$8,000 (\$248,000 - \$240,000). If Tenant expends \$150,000, the Credit shall be \$88,000 (\$248,000 - \$150,000, capped at \$88,000).

M  
A



**EXHIBIT D**

**V.A. CLINIC ASSOCIATES**

**ESTOPPEL CERTIFICATE**

With reference to that certain lease (the "Lease") dated \_\_\_\_\_, 1997, between V.A. CLINIC ASSOCIATES, a Nevada limited partnership ("Landlord"), and UNIVERSITY OF NEVADA SCHOOL OF MEDICINE MULTI-SPECIALTY GROUP PRACTICE SOUTH, INC., a Nevada corporation ("Tenant"), you are hereby notified of the following. All capitalized terms not otherwise defined herein shall have the same meaning as set forth in the Lease.

The undersigned Tenant certifies as follows to Landlord, its actual and prospective assignees and lenders, and all actual and prospective purchasers of the Building (each of whom is irrevocably entitled to rely on this Estoppel Certificate):

1. A true, correct, and complete copy of the Lease (including all riders, attachments, amendments, and/or exhibits thereto) is attached to this instrument as Attachment I and represents the entire agreement between the Landlord and Tenant relating to the Premises. There are no oral or other written agreements between Landlord and Tenant relating to the Premises or the transaction contemplated by the Lease.

2. Tenant has accepted possession of the Demised Premises under the lease, and the term of the Lease commenced on \_\_\_\_\_, 19\_\_ and will expire on \_\_\_\_\_, \_\_\_\_.

3. By the terms of the Lease, Tenant is presently obligated to pay, without present right of defense or offset, monthly base rent of \$\_\_\_\_\_. Additionally, Tenant is to reimburse Landlord for \_\_\_\_\_. Tenant has no claim against Landlord for any rent paid more than thirty (30) days in advance or any deposits or other sums other than \_\_\_\_\_.

4. Any improvements contemplated by the Lease have been contemplated in their entirety in accordance with the terms of the Lease, except for \_\_\_\_\_.

5. The address for notice to Tenant under the Lease is correct as of the date hereof.

6. Tenant has no right of first refusal, option, or other right to purchase the Premises or any part thereof, including, without limitation, the Premises.

*ML*  
*ML*  
*ML*  
**PLEASE INITIAL**

7. The execution of the Lease was duly authorized by Tenant, is in full force and effect, and is valid, binding, and enforceable against Tenant in accordance with its terms. There exists no default, nor state of facts which with notice, the passage of time, or both, could mature into a default on the part of either Tenant or Landlord.

8. There has not been filed by or against nor, to Tenant's best knowledge and belief, is there threatened against or contemplated by Tenant, a petition in bankruptcy, voluntary or otherwise, any assignment for the benefit of creditors, any petition seeking reorganization or arrangement under the bankruptcy laws of the United State or any state thereof, or any other action brought under said bankruptcy laws.

9. Tenant has obtained all necessary governmental licenses and permits required to lawfully conduct its business at the Premises, including, but not limited to, business, department of health, and safety licenses or permits.

10. Tenant has not assigned or otherwise transferred its interest in the Lease to any party or sublet any portion of the Premises.

11. By the terms of the Lease, Tenant has the option to renew the Lease for two (2) additional periods, beginning on the day next following the expiration date of the initial seven (7) year Lease term and continuing for five (5) years thereafter for each such additional period.

Except as may be amended herein, all terms and conditions of the Lease shall continue in full force and effect and are hereby republished, ratified, and reaffirmed in their entirety. This Certificate shall be binding upon and may be relied upon by the parties hereto and their respective legal representatives, successors, and assigns.

IN WITNESS WHEREOF, the parties have executed this Certificate as of the day and year first above written.

**LANDLORD:**

**V.A. CLINIC ASSOCIATES,**  
a Nevada limited partnership

\_\_\_\_\_  
By: Mark L. Fine  
General Partner

**TENANT:**

**UNIVERSITY OF NEVADA SCHOOL OF MEDICINE  
MULTI-SPECIALTY GROUP PRACTICE SOUTH, INC.,**  
a Nevada corporation

\_\_\_\_\_  
By: David V. Schapira, M.D., President

**APPROVED:**

University of Nevada School of Medicine  
Integrated Clinical Services, Inc., a Nevada corporation

\_\_\_\_\_  
By: Robert M. Daugherty M.D., Ph.D., President





EXHIBIT E-1

SUBORDINATION, ATTORNMENT AND NON-DISTURBANCE AGREEMENT

THIS AGREEMENT is made as of \_\_\_\_\_, 1998, by and among V.A. CLINIC ASSOCIATES ("Landlord") and UNIVERSITY OF NEVADA SCHOOL OF MEDICINE MULTI-SPECIALTY GROUP PRACTICE SOUTH, INC. ("Tenant"), and \_\_\_\_\_ (the "Beneficiary") whose address is \_\_\_\_\_

A. The Property. The term "Property", as used herein, shall mean the real property situated in the County of Clark, State of Nevada, legally described in Exhibit "A" attached hereto and by this reference made a part hereof, together with all buildings, structures, improvements and fixtures now or hereafter located thereon, and together with all easements and other rights appurtenant thereto.

B. The Lease. Pursuant to the terms and provisions of a lease dated \_\_\_\_\_, between Landlord and Tenant (the "Lease"), for an initial term of five (5) years, the Property has been leased to Tenant.

C. The Loan; Security Documents; Deed of Trust. Landlord proposes to borrow certain sums from Beneficiary to be evidenced by a promissory note. Landlord proposes to encumber the Property as security for payment of its obligations to Beneficiary and, for such purpose, shall enter into various instruments and documents (collectively the "Security Documents"), including without limitation a Deed of Trust and Security Agreement (the "Deed of Trust") from Landlord for the use and benefit of the Beneficiary and an Assignment of Landlord's Interest in Lease (the "Collateral Assignment"), which Deed of Trust and Collateral Assignment will be recorded in the real property records of Clark County, Nevada.

D. Purposes. In connection with the above-mentioned transactions, Landlord and Tenant have agreed to offer certain assurances and representations to the Beneficiary, and all parties agree to provide for (i) the subordination of the Lease to the Security Documents; (ii) the continuation of the Lease notwithstanding any foreclosure of the Deed of Trust subject to certain conditions; and (iii) Tenant's attornment to the Beneficiary or to such other parties as may acquire title to the Property as the result of any foreclosure or any conveyance of the Property in lieu of foreclosure.

AGREEMENT

NOW, THEREFORE, in consideration of the mutual terms and provisions hereinafter contained and other good and valuable consideration received by any party from any other, the receipt and sufficiency of which are hereby acknowledged, the parties agree as follows:

1. Notice of Default to Beneficiary. Notwithstanding anything to the contrary contained in the Lease, Tenant shall personally deliver or mail to Beneficiary, at Beneficiary's address set forth above, written notice of any default under the Lease by Landlord, and if within the time provided in the Lease for curing thereof by Landlord, Beneficiary performs or causes to be performed all such obligations with respect to which Landlord is in default which can be cured by the payment of money, any right of Tenant to terminate the Lease by reason of such default shall cease and be null and void.

MM  
PLEASE INITIAL

2. Subordination of Lease to Security Documents. Tenant hereby subordinates its leasehold estate in the Property and all of Tenant's right under the Lease to the Security Documents and to all extensions, renewals, modifications, consolidations and replacements thereof, to the full extent of all obligations secured or to be secured thereby including interest thereon and any future advances thereunder.

3. Non-Disturbance of Tenant. Beneficiary agrees that, for so long as Tenant shall perform and satisfy all obligations of Tenant under the Lease in accordance with its terms, neither the Lease nor Tenant's rights pursuant thereto shall be disturbed or affected by any foreclosure of the Deed of Trust or conveyance in lieu of foreclosure.

4. Beneficiary as Landlord after Foreclosure. In the event that Beneficiary (or any other party) shall acquire title to the Property or shall succeed to Landlord's interest in the Lease, whether through foreclosure of the Deed of Trust, conveyance in lieu of foreclosure, or otherwise, Beneficiary (or such other party) shall thereupon, and without the necessity of attornment or other act or agreement, be substituted as Tenant's landlord under the Lease, and shall be entitled to the rights and benefits and subject to the obligations thereof; provided that neither Beneficiary nor any other party shall be:

- (a) liable for any act or omission of any prior landlord under the Lease (including Landlord); or
- (b) subject to any offsets or defenses which Tenant might have against any prior landlord (including Landlord) except those which arose out of such landlord's default under the Lease and accrued after Tenant notified Beneficiary and gave it the opportunity to cure required in the Lease; or
- (c) bound by Tenant's payment of any rent or additional rent beyond the then current rent period to any prior landlord under the Lease (including Landlord); or
- (d) bound by any amendment, modification, extension or supplement of the Lease made without Beneficiary's prior written consent;

and Tenant hereby agrees to attorn to and recognize such Beneficiary (or such other party) as Tenant's landlord.

5. Payment of Rent Upon Default. Tenant has been advised that the Security Documents give Beneficiary the right to collect rent and other sums payable under the Lease directly from Tenant upon the occurrence of a default thereunder, and that upon the receipt from Beneficiary of notice of any such default, Tenant will thereafter pay all rent and other sums payable under the Lease directly (or as Beneficiary shall direct) as they become due and payable.

6. Application of Insurance and Condemnation Proceeds. Tenant has been advised that the insurance and condemnation provisions of the Security Documents give Beneficiary certain rights to require that insurance and condemnation proceeds be applied to payment of the indebtedness secured thereby and not to restoration or rebuilding; and Tenant hereby waives any terms of such Lease with respect to the application of insurance and condemnation proceeds which are inconsistent with the terms of the Security Documents.

7. Binding Effect. The provisions of this Agreement shall be covenants running with the Property, and shall be binding upon and shall inure to the benefits of the parties hereto and their respective heirs, representatives, successors and assigns.





IN WITNESS WHEREOF, the parties have executed this Agreement as of the day and year first above written.

LANDLORD:

TENANT:

V.A. CLINIC ASSOCIATES,  
a Nevada limited partnership

UNIVERSITY OF NEVADA SCHOOL OF MEDICINE  
MULTI-SPECIALTY GROUP PRACTICE SOUTH, INC.,  
a Nevada corporation

\_\_\_\_\_  
Mark L. Fine, General Partner

\_\_\_\_\_  
By: David V. Schapira, M.D., President

APPROVED:

University of Nevada School of Medicine  
Integrated Clinical Services, Inc.,  
a Nevada corporation

\_\_\_\_\_  
By: Robert M. Daugherty M.D., Ph.D., President



EXHIBIT "E-2"

**CONSENT TO SUB-LEASE, ATTORNMENT AND NON-DISTURBANCE AGREEMENT**

THIS CONSENT TO SUB-LEASE, ATTORNMENT AND NON-DISTURBANCE AGREEMENT (this "Agreement") is made this \_\_\_\_ day of \_\_\_\_\_, \_\_\_\_ by and among SANDRA BUSHROE and LINDA MAY ZOELLER, successors-in-interest to DODD SMITH (collectively with its assignee(s), "Landlord"), V.A. CLINIC ASSOCIATES, a Nevada limited partnership, successor-in-interest to MARCUS R. DURLACH, III (collectively, with its assignee(s), "Tenant") and UNIVERSITY OF NEVADA SCHOOL OF MEDICINE MULTI-SPECIALTY GROUP PRACTICE SOUTH, INC. ("Sub-Tenant") with respect to:

(i) that certain Lease Agreement dated August 16, 1978 (the "Main Lease," and the premises subject thereto, the "Premises") made by and between Landlord and Tenant; and (ii) that certain Lease Agreement dated \_\_\_\_\_ made by and between Landlord and Tenant; and (iii) such other leases or sub-leases after the termination of the Sub-Lease (collectively with the Sub-Lease, the "Sub-Leases") which Tenant may enter into during the term of the Main Lease with other sub-tenants, after termination of the Sub-Lease (collectively with Sub-Tenant, the "Sub-Tenants").

NOW, THEREFORE, the parties agree as follows:

1. *Consent to Sub-Leases; Subordination.* Landlord hereby consents to the Sub-Leases of the Premises to Sub-Tenants.

2. *Attornment; payments after Tenant default.* Sub-Tenants shall attorn to and recognize the Landlord as the Landlord under the Main Lease, for the unexpired balance (and any extensions, if exercised) of the Sub-Leases, effective on the date the Sub-Tenants receive notice from the Landlord that the Tenant is in default under the Main Lease. After receipt of such notice from Landlord, Tenant agrees that Sub-Tenants may pay to Landlord, or at the direction of Landlord, all monies due or to become due to Landlord under the Main Lease. Tenant hereby waives any right, claim, or demand it may now have or hereafter have against Sub-Tenants by reason of such payment(s) under the Main Lease to Landlord, and any such payment(s) shall discharge and reduce the obligation of Sub-Tenants to pay rent to Tenant under the Sub-Leases, as to the amount of such payment(s) made directly to Landlord.

3. *Non-Disturbance.* If the Main Lease is terminated for any reason prior to the expiration of its term, such termination shall not terminate nor affect the validity of the Sub-

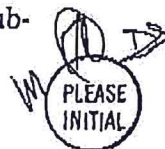



**FIRST AMENDMENT**

THIS FIRST AMENDMENT (the "First Amendment") is entered into this \_\_\_ day of \_\_\_\_\_, 2009, by and between V.A. CLINIC ASSOCIATES, a Nevada limited partnership ("Landlord") UNIVERSITY OF NEVADA SCHOOL OF MEDICINE MULTI-SPECIALTY GROUP PRACTICE SOUTH, INC., a Nevada corporation ("Tenant").

**RECITALS:**

A. Landlord and Tenant entered into that certain Lease Agreement dated January 20, 1998 (the "Lease"), for a building located at 1703 West Charleston Blvd., City of Las Vegas, County of Clark, State of Nevada (as more specifically defined therein, the "Premises"). Capitalized terms used herein and not otherwise defined shall have the meanings which are set forth in the Lease.

B. Landlord and Tenant have agreed to amend the Lease as set forth herein.

NOW THEREFORE, based upon the covenants and promises contained herein and other good and valuable consideration, Landlord and Tenant mutually agree as follows:

1. The date by which Tenant must exercise its second option to extend, if at all, pursuant to Article 2 of the Lease is hereby postponed from November 30, 2009 to and until May 31, 2010. The purpose of such postponement shall be to allow Landlord and Tenant to enter into discussions concerning additional renewal options and other matters affecting the Lease (the "Lease Discussions").

2. The Term of the Lease is hereby extended for an extension period beginning on December 1, 2010 and continuing to and until the earlier of (i) May 31, 2011, or (ii) the date which is three hundred eighty-five (385) days after either Landlord or Tenant gives notice to the other that it is withdrawing from further Lease Discussions (which either party shall the right to do at any time in its sole and absolute discretion) (the "Extension Period").

3. During the Extension Period, Landlord shall have no obligation to make repairs described in Paragraphs 11(a) or 11(b) of the Lease, but all other terms and conditions of the Lease shall continue to apply.

4. Except as modified herein, the Lease shall remain in full force and effect.

IN WITNESS WHEREOF, this First Amendment has been executed on the day and year above written.

“LANDLORD”

V.A. CLINIC ASSOCIATES,  
A Nevada limited partnership

By: \_\_\_\_\_  
Name: Mark L. Fine  
Its: General Partner

“TENANT”

UNIVERSITY OF NEVADA SCHOOL OF MEDICINE  
MULTI-SPECIALTY GROUP PRACTICE SOUTH, INC.,  
A Nevada corporation

By:   
Name: Ronald M. Zurek  
Its: Vice President for Administration and Finance



"LANDLORD"

V.A. CLINIC ASSOCIATES,  
A Nevada limited partnership

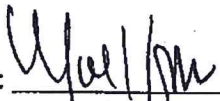
By:   
Name: Mark L. Fine  
Its: General Partner

"TENANT"

UNIVERSITY OF NEVADA SCHOOL OF MEDICINE  
MULTI-SPECIALTY GROUP PRACTICE SOUTH, INC.,  
A Nevada corporation

By: \_\_\_\_\_  
Name: \_\_\_\_\_  
Its: \_\_\_\_\_

**SECOND AMENDMENT**

THIS SECOND AMENDMENT (the "Second Amendment") is entered into this 1<sup>st</sup> day of June, 2010, by and between V.A. CLINIC ASSOCIATES, a Nevada limited partnership ("Landlord"), and UNIVERSITY OF NEVADA SCHOOL OF MEDICINE MULTI-SPECIALTY GROUP PRACTICE SOUTH, INC., a Nevada corporation ("Tenant").

**RECITALS:**

A. Landlord and Tenant entered into that certain Lease Agreement dated January 20, 1998 (as amended by a certain First Amendment dated as of January 18, 2010, the "Lease"), for a building located at 1703 West Charleston Blvd., City of Las Vegas, County of Clark, State of Nevada (as more specifically defined therein, the "Premises"). Capitalized terms used herein and not otherwise defined shall have the meanings which are set forth in the Lease.

B. Landlord and Tenant have agreed to amend the Lease as set forth herein.

NOW THEREFORE, based upon the covenants and promises contained herein and other good and valuable consideration, Landlord and Tenant mutually agree as follows:

1. By its execution of this Second Amendment, Tenant is exercising its second option to extend the term of the Lease, and the term of the Lease is hereby extended, for an extension term beginning on June 1, 2011 and expiring on May 31, 2016 (the "Extension Term").

2. Pursuant to Article 4 of the Lease and Paragraph 3 of the First Amendment, monthly rent shall increase on December 1, 2010 to \$66,550 per month. On December 1, 2015, monthly rent shall increase by ten percent (10%) to \$73,205 per month.

3. Tenant is hereby given the option to extend the term of the Lease on all of the provisions contained in the Lease, except for fixed rent, which shall be determined pursuant to Paragraph 4 below, and except for Landlord's repair obligations, which shall be amended pursuant to Paragraph 5 below, for two (2) additional consecutive periods of five (5) years following the expiration of the Extension Term; provided that on the date the applicable extended term is to commence Tenant shall not be in default under this Lease (after receipt by Tenant of any notice required under the terms of this Lease and beyond any cure period provided for in this Lease and after an additional notice, stating Landlord's intent to cancel the extension of the Lease by Tenant as a result of such default, and the lapse of an additional twenty (20) days without cure by Tenant after such additional notice). To exercise the first such option to extend, Tenant shall give Landlord written notice of exercise of such option no later than May 31, 2015. To exercise the second such option to extend, Tenant shall give Landlord written notice of exercise of such option no later than May 31, 2020. Notwithstanding anything to the contrary contained in this Lease, if Tenant fails to give any such notice of exercise within the time provided herein, Tenant shall not be deemed to have waived the applicable option to extend



unless and until Landlord shall have given Tenant written notice of such failure and such failure continues for a period for twenty (20) days after Tenant's receipt of such notice. In the event that on the date the applicable extended term is to commence Tenant shall be in default under this Lease (after receipt by Tenant of any notice required under the terms of this Lease and beyond any cure period provided for in this Lease), at Landlord's option, the extended term shall not commence and this Lease shall thereupon expire. All references in this Lease to the term shall mean the initial term, as extended by the Extension Term and as further extended by any option pursuant to this paragraph.

4. If Tenant exercises its first renewal option pursuant to Paragraph 3 above, monthly rent shall increase by ten percent (10%) to \$80,525 on December 1, 2020. If Tenant exercises its second renewal option pursuant to Paragraph 3 above, monthly rent shall increase by ten percent (10%) to \$88,578 on December 1, 2025.

5. If Tenant exercises its first renewal option pursuant to Paragraph 3 above, then, effective as of the commencement of that renewal option term on June 1, 2016, the amount of Twenty-Five Hundred Dollars (\$2,500) set forth in Paragraphs 11(a) and 11(b) of the Lease shall increase to Forty-Five Hundred Dollars (\$4,500) (hereinafter the "Repair Threshold Amount"). On June 1, 2017 and on June 1 of each year thereafter during the term of the Lease as the same may be extended, the Repair Threshold Amount shall increase by three and one-half percent (3.5%) of the Repair Threshold Amount in effect for the prior year.

6. Concurrently with the execution of this Second Amendment, Landlord and Tenant and University of Nevada, Reno, which is an affiliate of Tenant, shall execute an Option Agreement and Escrow Instructions granting Tenant and such affiliate the option to purchase the Premises and a right of first offer to purchase the Premises upon the terms and subject to the conditions which are set forth therein.

7. Except as modified herein, the Lease shall remain in full force and effect.

8. This Second Amendment may be executed in any number of counterparts, each of which shall be deemed an original, and all of which together shall constitute one agreement. This Second Amendment, signed and transmitted by facsimile machine or pdf file, is to be treated as an original document and the signature of any party hereon, if so transmitted, is to be considered as an original signature, and the document so transmitted is to be considered to have the same binding effect as a manually executed original.

IN WITNESS WHEREOF, this Second Amendment has been executed on the day and year above written.

[Signatures on Next Page]

"LANDLORD"

V.A. CLINIC ASSOCIATES,  
A Nevada limited partnership

By:   
Name: Mark L. Fine  
Its: General Partner

"TENANT"

UNIVERSITY OF NEVADA SCHOOL OF MEDICINE  
MULTI-SPECIALTY GROUP PRACTICE SOUTH, INC.,  
A Nevada corporation

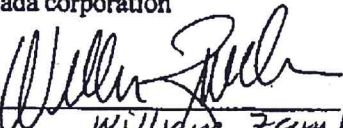
By:   
Name: William Zamboni  
Its: MSA(S) UNISON



### THIRD AMENDMENT

THIS THIRD AMENDMENT (the "**Third Amendment**") is entered into this 16 day of March, 2014,<sup>5</sup> by and between V.A. CLINIC ASSOCIATES, a Nevada limited partnership ("**Landlord**"), and UNIVERSITY OF NEVADA SCHOOL OF MEDICINE MULTI-SPECIALTY GROUP PRACTICE SOUTH, INC., a Nevada corporation ("**Tenant**").

#### RECITALS:

A. Landlord and Tenant entered into that certain Lease Agreement dated January 20, 1998, as amended by a certain First Amendment dated as of January 18, 2010 and that certain Second Amendment dated as of June 1, 2010 (collectively, the "**Lease**"), for a Building located at 1707 West Charleston Blvd., City of Las Vegas, County of Clark, State of Nevada (as more specifically defined therein, the "**Premises**"), upon a portion of the Land located at 1703-1707 W. Charleston Boulevard, Las Vegas, Nevada, and more particularly described in the Lease, consisting of approximately 2.79 acres. Capitalized terms used herein and not otherwise defined shall have the meanings which are set forth in the Lease.

B. Tenant wishes to construct a stairway and ramp to provide access to and from the Building and other premises leased by Tenant in the building located at 1701 W. Charleston Boulevard, as shown on Exhibit "A" attached hereto and by this reference made a part hereof ("**Stairway/Ramp**"). Landlord is willing to approve the Stairway/Ramp, provided that Tenant agrees to the terms and conditions hereof.

NOW THEREFORE, based upon the covenants and promises contained herein and other good and valuable consideration, Landlord and Tenant mutually agree as follows:

1. **Construction.** Tenant agrees to construct the Stairway/Ramp (the "**Tenant Work**") in a good and workmanlike manner in and upon the Land, at Tenant's sole cost and expense, in accordance with the following provisions. Tenant shall submit to Landlord for Landlord's approval complete plans and specifications for the construction of the Tenant Work ("**Tenant's Plan**"). Within 10 business days after receipt of Tenant's Plan, Landlord shall review and either approve or disapprove Tenant's Plan. If Landlord disapproves Tenant's Plan, or any portion thereof, Landlord shall notify Tenant thereof and of the revisions Landlord requires before Landlord will approve Tenant's Plan. Within 10 business days after Landlord's notice, Tenant shall submit to Landlord, for Landlord's review and approval, plans and specifications incorporating the required revisions. The final plans and specifications approved by Landlord are hereinafter referred to as the "**Approved Construction Documents**". Tenant will employ experienced, licensed contractors, architects, engineers and other consultants, to construct the Tenant Work and will require in the applicable contracts that such parties (a) carry insurance in such amounts and types of coverages as are reasonably required by Landlord, and (b) design and construct the Tenant Work in a good and workmanlike manner and in compliance with all applicable laws, including, without limitation, the Americans with Disabilities Act (the "**ADA**"). Tenant shall obtain from its contractors and provide to Landlord a list of all subcontractors



providing labor or materials in connection with any portion of the Tenant Work prior to commencement of the Tenant Work. Tenant warrants that the design, construction and installation of the Tenant Work shall conform to the requirements of all applicable laws (including, without limitation, the ADA) and the requirements of any authority having jurisdiction over, or with respect to, such Tenant Work. Tenant shall reimburse Landlord, within fifteen (15) days after written demand therefor, for all reasonable out-of-pocket costs and expenses which may be incurred by Landlord in connection with the Stairway/Ramp, including without limitation, architect's fees charged for the review of Tenant's Plan and attorneys' fees incurred in connection with the preparation of this Third Amendment.

2. **Lien Waivers.** Tenant shall provide to Landlord (i) third-party invoices for costs incurred by Tenant in constructing the Tenant Work; (ii) evidence that Tenant has paid the invoices for such costs; and (iii) lien waivers from any contractor or supplier who has constructed or supplied materials for the Tenant Work. Tenant agrees to keep the Building and the Land free from any liens arising out of the construction of the Tenant Work.

3. **Assumption of Risk and Waiver.** FOR THE TERM OF THE LEASE, TENANT HEREBY ASSUMES ANY AND ALL RISKS INVOLVED WITH RESPECT TO THE TENANT WORK AND HEREBY RELEASES AND DISCHARGES LANDLORD FROM ANY AND ALL LIABILITY OR LOSS, DAMAGE OR INJURY SUFFERED OR INCURRED BY TENANT OR THIRD PARTIES IN ANY WAY ARISING OUT OF OR IN CONNECTION WITH THE TENANT WORK.

4. **Insurance.** Tenant shall maintain a commercial general liability insurance policy covering Tenant's liability related to bodily injury and property damages arising from the Tenant Work. Tenant shall have the Landlord named as an additional insured on such insurance policy and shall provide Landlord proof of such status prior to construction of the Tenant Work.

5. **Maintenance.** Once constructed, the Stairway/Ramp shall be considered a leasehold improvement and shall be maintain by Tenant in good working order and free from waste, litter and any condition that is offensive to the public health, safety and welfare.

6. **Removal.** Upon the expiration or earlier termination of the Lease, Landlord shall have the right to require Tenant to remove the Stairway/Ramp, restore any damage caused by such removal and repair and restore the landscaping, curbing, signage and other improvements upon the Land to substantially the same condition as existed immediately prior to the Tenant Work (collectively, the "**Removal Work**"), all at Tenant's cost and expense. If Landlord does not require removal of the Stairway/Ramp upon the expiration or earlier termination of the Lease, the Stairway/Ramp shall become the sole property and responsibility of the Landlord. The Removal Work, if required by Landlord, shall be completed within thirty (30) days after the expiration or earlier termination of the Lease in accordance with plans for such work which are prepared and stamped by a licensed structural engineer engaged by Tenant (if and to the extent reasonably required by the matters of such work) and which are otherwise acceptable to Landlord and a permit for such work from the appropriate authority shall be obtained by Tenant. The Removal Work shall not be deemed to be completed until Tenant delivers to Landlord (i) a certificate from Tenant's licensed structural engineer stating that such work has been completed in accordance with the approved plans, and (ii) proof of final inspection and approval from the appropriate authority. In the alternative, Landlord may elect to have Landlord's contractor perform the Removal Work at Tenant's cost. If Landlord elects to have Landlord's contractor



perform such work, Tenant shall pay the cost thereof, including all fees for permits and engineering and architectural services incurred by Landlord in connection with the Removal Work, within thirty (30) days after invoice from Landlord. Tenant's obligations in this Section 6 shall survive the expiration or earlier termination of the Lease.

7. **Effect of Amendment.** Except as modified herein, the Lease shall remain in full force and effect.

8. **Counterparts.** This Third Amendment may be executed in any number of counterparts, each of which shall be deemed an original, and all of which together shall constitute one agreement. This Third Amendment, signed and transmitted by facsimile machine or pdf file, is to be treated as an original document and the signature of any party hereon, if so transmitted, is to be considered as an original signature, and the document so transmitted is to be considered to have the same binding effect as a manually executed original.

IN WITNESS WHEREOF, this Third Amendment has been executed on the day and year above written.

"LANDLORD"

V.A. CLINIC ASSOCIATES,  
A Nevada limited partnership

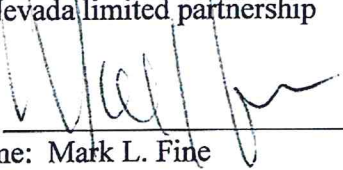
By:   
Name: Mark L. Fine  
Its: General Partner

"TENANT"

UNIVERSITY OF NEVADA SCHOOL OF MEDICINE  
MULTI-SPECIALTY GROUP PRACTICE SOUTH, INC.,  
A Nevada corporation

By: \_\_\_\_\_  
Name: \_\_\_\_\_  
Its: \_\_\_\_\_

perform such work, Tenant shall pay the cost thereof, including all fees for permits and engineering and architectural services incurred by Landlord in connection with the Removal Work, within thirty (30) days after invoice from Landlord. Tenant's obligations in this Section 6 shall survive the expiration or earlier termination of the Lease.

7. **Effect of Amendment.** Except as modified herein, the Lease shall remain in full force and effect.

8. **Counterparts.** This Third Amendment may be executed in any number of counterparts, each of which shall be deemed an original, and all of which together shall constitute one agreement. This Third Amendment, signed and transmitted by facsimile machine or pdf file, is to be treated as an original document and the signature of any party hereon, if so transmitted, is to be considered as an original signature, and the document so transmitted is to be considered to have the same binding effect as a manually executed original.

IN WITNESS WHEREOF, this Third Amendment has been executed on the day and year above written.

"LANDLORD"

V.A. CLINIC ASSOCIATES,  
A Nevada limited partnership

By: \_\_\_\_\_  
Name: Mark L. Fine  
Its: General Partner

"TENANT"

UNIVERSITY OF NEVADA SCHOOL OF MEDICINE  
MULTI-SPECIALTY GROUP PRACTICE SOUTH, INC.,  
A Nevada corporation

By: *Elissa J. Palmer MD*  
Name: Elissa J. Palmer MD  
Its: MSAS Vice President



EXHIBIT A

DESCRIPTION OF STAIRWAY/RAMP

[to be attached]





W. CHARLESTON BLVD.

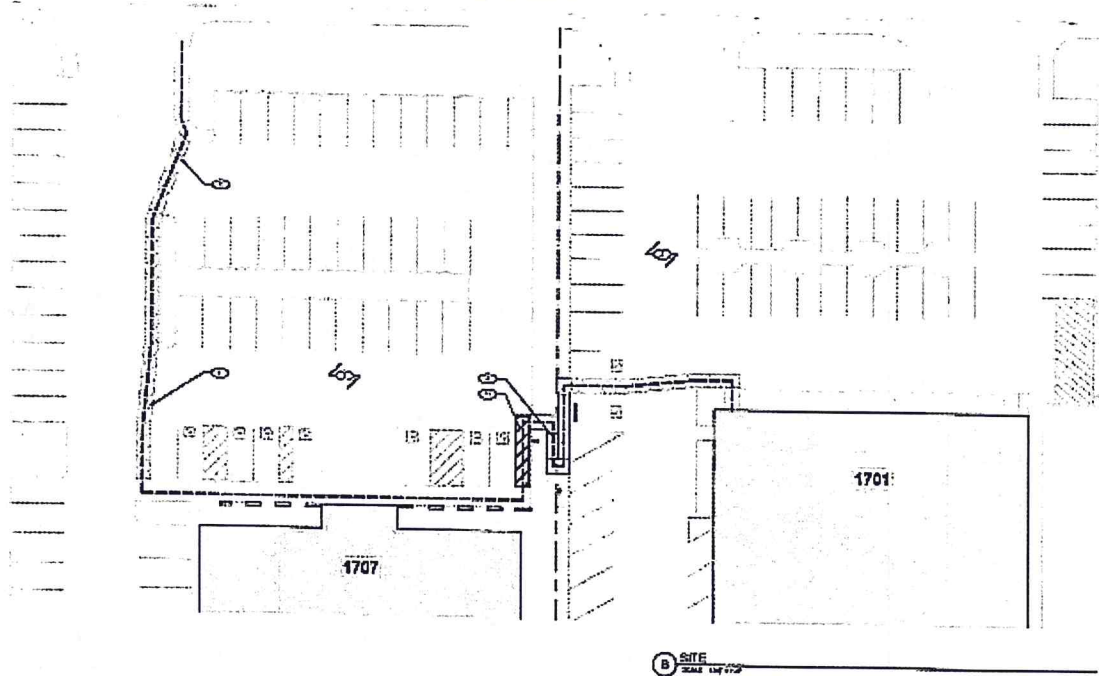

**B SITE**  
SCALE 1/4" = 1'-0"

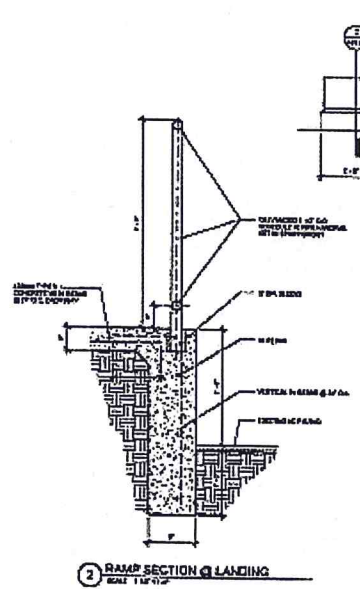

**2 RAMP SECTION & LANDING**  
SCALE 1/4" = 1'-0"

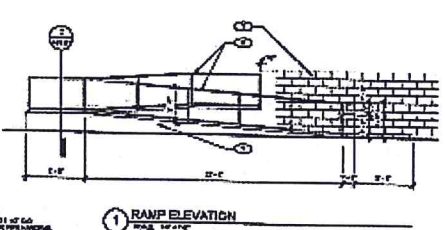

**1 RAMP ELEVATION**  
SCALE 1/4" = 1'-0"

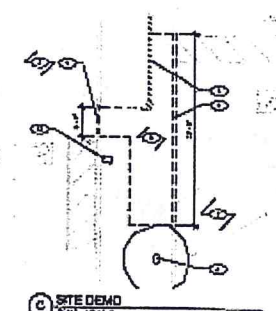

**C SITE DEMO**  
SCALE 1/4" = 1'-0"

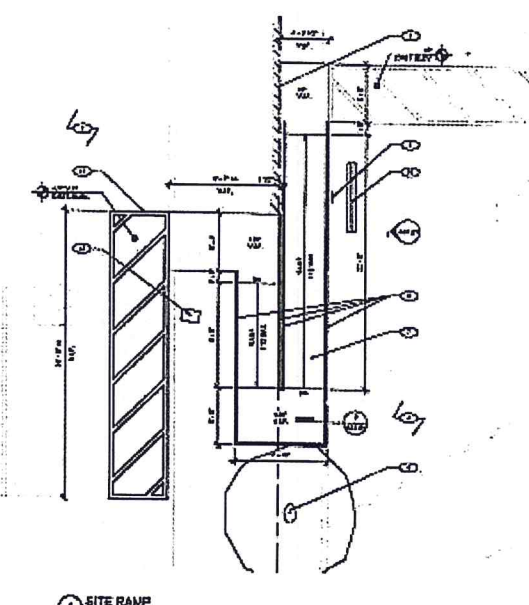

**A SITE RAMP**  
SCALE 1/4" = 1'-0"

<p>DATE: 03/03/16                  PROJECT: UNR - ACCESSIBLE RAMP                  1701 W. CHARLESTON</p>	
<p>1 DISTINGUISHABLE SPACE TO REMAIN FOR CYCLING TO REMAIN LANDSCAPING TO REMAIN</p> <p>2 DISTINGUISHABLE SPACE TO REMAIN LANDSCAPING TO REMAIN</p>	<p>ARCHITECT: <b>TATE SNYDER KIMSEY</b></p> <p>PLANNING: <b>TECNCLL</b></p>
<p>REVISIONS</p> <p>1 EXISTING ACCESSIBLE ROUTE TO PUBLIC WAY</p> <p>2 EXISTING PARKING</p> <p>3 EXISTING CURB WALL TO FORM</p> <p>4 EXISTING TRAC TO FORM</p> <p>5 EXISTING CURB TO FORM</p> <p>6 EXISTING CURB TO FORM</p> <p>7 EXISTING CURB TO FORM</p> <p>8 EXISTING CURB TO FORM</p> <p>9 EXISTING CURB TO FORM</p> <p>10 EXISTING CURB TO FORM</p> <p>11 EXISTING CURB TO FORM</p> <p>12 EXISTING CURB TO FORM</p> <p>13 EXISTING CURB TO FORM</p>	
<p>DATE: 03/03/16                  PROJECT: UNR - ACCESSIBLE RAMP                  1701 W. CHARLESTON</p>	
<p>SCALE: 1/4" = 1'-0"</p>	

## Exhibit 2

### FOURTH AMENDMENT AND ASSIGNMENT OF LEASE

THIS FOURTH AMENDMENT AND ASSIGNMENT OF LEASE (the "Fourth Amendment") is entered into this \_\_\_ day of \_\_\_\_\_, 2015 (the "Effective Date"), by and between V.A. CLINIC ASSOCIATES, LLC, a Nevada limited liability company ("Landlord"), and, BOARD OF REGENTS OF THE NEVADA SYSTEM OF HIGHER EDUCATION ON BEHALF OF THE UNIVERSITY OF NEVADA SCHOOL OF MEDICINE, ("Tenant" or "NSHE") and the University of Nevada School of Medicine Multi-Specialty Group Practice South, Inc., a Nevada corporation ("Practice Group").

#### RECITALS:

A. Landlord and Practice Group entered into that certain Lease Agreement dated January 20, 1998, as amended by a certain First Amendment dated as of January 18, 2010, that certain Second Amendment dated as of June 1, 2010 and that certain Third Amendment dated March 16, 2015 (collectively, the "Lease", copies of which are attached as Exhibit A), for a Building located at 1707 West Charleston Blvd., City of Las Vegas, County of Clark, State of Nevada (as more specifically defined therein, the "Premises"), upon a portion of the Land located at 1703-1707 W. Charleston Boulevard, Las Vegas, Nevada, and more particularly described in the Lease, consisting of approximately 2.79 acres. Capitalized terms used herein and not otherwise defined shall have the meanings which are set forth in the Lease.

B. Practice Group desires to assign the Lease to NSHE, Landlord consents to such assignment, and NSHE desires to accept the assignment of the Lease.

C. In addition, NSHE desires to exercise the first option to extend the term of the Lease pursuant to Paragraph 3 of the Second Amendment.

Therefore, based upon the covenants and promises contained herein and other good and valuable consideration, Landlord, NSHE and Practice Group mutually agree as follows:

#### TERMS AND CONDITIONS:

1. Practice Group does hereby assign, transfer, and deliver to NSHE the entire interest of Practice Group in the Lease. Landlord consents to such assignment, transfer and delivery of the Lease to NSHE and, pursuant to Paragraph 23 of the Lease, releases Practice Group from continued performance of the terms and provisions of the Lease as of the Effective Date. Practice Group and Landlord represent and warrant, for the benefit of NSHE, that: (a) the Lease is in full force and effect and has not been modified except as provided in Exhibit A; and (b) there are no uncured defaults under the Lease nor does there exist any event or condition which, with notice or the passage of time or both, could constitute a default under the Lease. All references in the Lease and in this Fourth Amendment to "Tenant" shall be deemed to mean and refer to NSHE.

2. The term of the Lease is hereby extended for a period of sixty (60) months commencing on June 1, 2016 (the "New Commencement Date"), and expiring on May 31, 2021 (the "Sixty Month Extension Period").

3. Pursuant to the Paragraphs 2 and 4 of the Second Amendment, monthly rent during the Sixty Month Extension Period shall be as follows:



Period	Monthly Rent
June 1, 2016 – November 30, 2020	\$73,205.00
December 1, 2020 – May 31, 2021	\$80,525.00

4. Tenant has one (1) remaining option to extend the term of the Lease pursuant to Paragraph 3 of the Second Amendment.

5. Landlord represents and warrants to Tenant, and Tenant represents and warrants to Landlord, that, no broker, leasing agent or finder has been engaged in connection with the transaction contemplated by this Fourth Amendment. However, in the event of any claims for brokers' or finders' fees or commissions in connection with this Fourth Amendment, Landlord and Tenant hereby indemnify and hold each other harmless against any loss, claim, expense or liability with respect to any commissions or brokerage fees claimed as a result of the execution of this Fourth Amendment and/or the renewal of this Lease due to any action of the indemnifying party.

6. Landlord acknowledges and agrees that, notwithstanding any other term or provision of the Lease, all or a portion of the Premises may be used by another institution of the Nevada System of Higher Education and that any such use is allowed as a matter of right and shall not constitute an assignment or sublease under Paragraph 23 of the Lease provided the Premises is used for office, research, child care, laboratory educational facilities, pharmacy, health clinic, retail or related office uses consistent with Paragraph 10 of the Lease.

7. Landlord acknowledges that Tenant is a constitutional entity of the State of Nevada, is self-insured, and that its tort liability is subject to the limitations set forth in Chapter 41 of the Nevada Revised Statutes. Notwithstanding any other term or provision of the Lease, Tenant may satisfy the insurance obligations set forth in Paragraph 7 of the Lease through policies of self-insurance.

8. Landlord acknowledges and agrees that Tenant's indemnification obligation under Paragraph 17 of the Lease is limited in accordance with Nevada Revised Statute 41.0305 to 41.039 and that Tenant may assert sovereign immunity and other available constitutional and statutory defenses.

9. Notwithstanding any other term or provision of the Lease, pursuant Article 9, Sec. 3 of the Nevada Constitution and NRS 353.260 or other applicable law, in the event the State of Nevada fails to appropriate funds to the Nevada System of Higher Education, the University of Nevada Reno, the University of Nevada School of Medicine, or divisions and departments thereof, to enable the obligations to be fulfilled under this Lease for the ensuing fiscal year or any part thereof, Tenant shall give Landlord notice of such failure to fund promptly after Tenant has knowledge thereof, and all rights and obligations of Tenant under this Lease shall terminate upon the later of (i) ninety (90) days written notice to Landlord of Tenant's intent to exercise this Fiscal Funding Out right or (ii) the first day of July of the fiscal year for which funds have not been appropriated. During the term of the Lease, Tenant shall use good faith efforts to obtain, or secure the appropriation of, funding from the applicable funding authority necessary for Tenant to operate in the ordinary course of business and to fulfill the obligations of Tenant under the Lease.

10. Except as modified herein, the Lease shall remain in full force and effect.

11. This Fourth Amendment may be executed in any number of counterparts, each of which shall be deemed an original, and all of which together shall constitute one agreement. This Fourth Amendment, signed and transmitted by facsimile machine or pdf file, is to be treated as an original document and the signature of any party hereon, if so transmitted, is to be considered as an original signature, and the document so transmitted is to be considered to have the same binding effect as a manually executed original.

This Fourth Amendment and Assignment of Lease has been executed as of the Effective Date written above.

V.A. CLINIC ASSOCIATES, LLC,  
a Nevada limited liability company

By: [Signature]  
Name: \_\_\_\_\_  
Its: \_\_\_\_\_

BOARD OF REGENTS OF THE NEVADA SYSTEM  
OF HIGHER EDUCATION ON BEHALF OF  
THE UNIVERSITY OF NEVADA SCHOOL OF MEDICINE,  
a constitutional entity of the State of Nevada

By: [Signature]  
Name: \_\_\_\_\_  
Its: 10/02/15

Thomas L. Schwenk, M.D.  
Vice President, Division of Health Sciences  
Dean, School of Medicine  
President, Integrated Clinical Services, Inc.

UNIVERSITY OF NEVADA SCHOOL OF MEDICINE  
MULTI-SPECIALTY GROUP PRACTICE SOUTH, INC.,  
a Nevada corporation

By: [Signature] MD  
Name: ELISSA J. PALMER M.D.  
Its: \_\_\_\_\_



**BOARD OF REGENTS OF THE NEVADA  
SYSTEM OF HIGHER EDUCATION  
ON BEHALF OF THE UNIVERSITY OF NEVADA  
SCHOOL OF MEDICINE**

By:   
Marc A. Johnson  
President, UNR

Date: 10-29-15

By: \_\_\_\_\_  
Daniel J. Klaich  
Chancellor, NSHE

Date: \_\_\_\_\_

Exhibit A

BRUCE A. LESLIE, CHTD.

002

07/27/05 09:58 FAX

Original Copy  
Copy 5 Of 6 Copies

**LEASE AGREEMENT**

**V.A. CLINIC ASSOCIATES,**

a Nevada limited partnership,

as Landlord

and

**UNIVERSITY OF NEVADA SCHOOL OF MEDICINE  
MULTI-SPECIALTY GROUP PRACTICE SOUTH, INC.,**

a Nevada corporation

as Tenant

Dated January 20, 1998



TABLE OF CONTENTS

	Page
Basic Lease Provisions .....	iii
1. PREMISES .....	1
2. TERM .....	2
3. PAYMENT OF RENT .....	2
4. RENT .....	2
5. LEASE CONTINGENCY .....	3
6. TAXES AND ASSESSMENTS .....	4
7. INSURANCE .....	5
8. UTILITIES .....	7
9. PARKING AREA .....	8
10. USE .....	8
11. REPAIRS .....	9
12. ALTERATIONS .....	11
13. EMINENT DOMAIN .....	11
14. DAMAGE AND DESTRUCTION .....	12
15. DEFAULT BY LANDLORD .....	13
16. TENANT'S DEFAULT .....	13
17. INDEMNIFICATION, RELEASE AND LIENS .....	17

18. NON-DISTURBANCE; SUBORDINATION AND FINANCING ..... 18

19. SURRENDER OF PREMISES ..... 19

20. CONSTRUCTION OF PREMISES; COOPERATION ..... 19

21. NOTICES ..... 19

22. ATTORNEY'S FEES ..... 20

23. ASSIGNMENT AND SUBLETTING ..... 20

24. ACCESS ..... 20

25. HOLDOVER ..... 20

26. INSOLVENCY OF TENANT ..... 21

27. SURRENDER OF LEASE ..... 21

28. SALE OF PREMISES BY LANDLORD ..... 21

29. SIGNS ..... 21

30. MISCELLANEOUS ..... 21

SIGNATURES ..... 23

EXHIBITS:

- A LEGAL DESCRIPTION
- B SITE PLAN
- C PROVISIONS REGARDING LANDLORD AND TENANT'S WORK AND LANDLORD'S CONSTRUCTION ALLOWANCE
- D ESTOPPEL CERTIFICATE
- E-1 SUBORDINATION, ATTORNMENMENT AND NON-DISTURBANCE AGREEMENT
- E-2 CONSENT TO SUB-LEASE, ATTORNMENMENT AND NONDISTURBANCE AGREEMENT



BASIC LEASE PROVISIONS

1. Landlord: V.A. Clinic Associates,  
a Nevada limited partnership
2. Landlord's Address For Payment of Rent and Notices: V.A. Clinic Associates  
2300 W. Sahara, Ste. 640  
P.O. Box 23  
Las Vegas, NV 89102  
Attn: Mark L. Finc  
Copy to: Peter C. Bernhard, Esq.  
Bernhard & Leslie, Chtd.  
3980 Howard Hughes Pkwy.  
Suite 550  
Las Vegas, NV 89109
3. Tenant: University of Nevada School of Medicine  
Multi-Specialty Group Practice South, Inc.
4. Tenant's Address For Notices: Jeffrey W. Wyatt  
2040 W. Charleston Blvd., Ste. 400  
Las Vegas, NV 89102  
Copy to: Craig H. Edgecumbe, Esq.  
2780 Skypark Drive, Ste. 325  
Torrance, CA 90505-5350
5. Land: That certain approximate 2.2 acre parcel of land situated in the City of Las Vegas, County of Clark, State of Nevada, as more particularly described in Exhibit A.
6. Improvements: A two (2) floor office building (the "Building") containing 44,824 rentable square feet of Floor Area, and 38,377 usable square feet of Floor Area, and all other improvements as shown on Exhibit B.
7. Term: Seven (7) years.
8. Estimated Commencement Date: July 15, 1998
9. Option Term: Two (2) option terms, each for Five (5) years.
10. Initial Term Base Rent Per Month: Fifty Five Thousand Dollars (\$55,000.00) during the initial seven year term.
11. Option Term Base Rent Per Month: 1st option term = \$60,500.00  
2nd option term = \$66,550.00
12. Permitted Uses: Any use consistent with an "A" class building.

The Basic Lease Provisions set forth above are incorporated into and made a part of the following Lease. Each reference in this lease to any of the Basic Lease Provisions shall mean the respective information above and shall be construed to incorporate all of the terms provided under the particular Lease paragraph pertaining to such information. In the event of any conflict between the Basic lease Provisions and the provisions of the Lease, the latter shall control.

LEASE AGREEMENT

THIS LEASE, executed this 20<sup>th</sup> day of JANUARY, 1998, by and between V.A. Clinic Associates, a Nevada limited partnership (hereinafter called "Landlord") and University of Nevada School of Medicine Multi-Specialty Group Practice South, Inc., a Nevada corporation, (hereinafter called "Tenant"), is entered into upon the terms and conditions set forth below.

1. Premises. The premises ("premises") leased hereunder are located in the City of Las Vegas, County of Clark, State of Nevada, commonly known as 1703<sup>rd</sup> West Charleston Blvd. The premises consist of (i) an existing building (the "building") having a total of approximately 44,824 square feet of total Floor Area, and 38,377 square feet of usable Floor Area, (ii) the parcel of real property described on Exhibit "A", and (iii) any and all other improvements thereon and appurtenances thereto, including without limitation, all vehicular parking areas and improvements, as shown on the Site Plan depicted on Exhibit "B".

Notwithstanding anything to the contrary contained herein, Landlord and Tenant recognize and agree that Landlord is the Lessee of an approximate 1/2 acre portion of the parking area under that certain Ground Lease dated August 16, 1978, between Dodd Smith as Ground Lessor and Landlord's predecessor-in-interest as Ground Lessee. Landlord hereby covenants and warrants to Tenant that Landlord shall at all times during the term of this Lease, including any option terms exercised hereunder, keep said Ground Lease in full force and effect so as to ensure that Tenant will have available at all times during the term hereof, the entire parcel of real property described in Exhibit A.

As used in this Lease, the term "Floor Area" with respect to any leasable area in the building shall be determined by adding (a) the aggregate number of square feet of floor space of all floor levels therein, measured from (i) the outside faces of all perimeter walls thereof; (ii) the outside face of any interior wall; and (iii) the building and/or lease line adjacent to any entrance to such leasable area (there being no deduction or exclusion from Floor Area by reason of columns, ducts, interior restrooms or other interior components); and (b) any area occupied by restrooms, lobby, utility rooms, janitorial rooms and interior stairways.

Notwithstanding the foregoing, Landlord reserves for its own use the right to locate one (1) antenna tower on a portion of the premises, to be constructed, maintained and operated by Landlord or Landlord's designee (including the right of ingress and egress over the premises for construction and maintenance), provided that the location, maintenance and operation of said tower does not deprive Tenant of the use and occupancy of the building, driveways, or any parking spaces or areas included



within this Lease. Said antenna tower shall be for cellular or other similar electronic transmissions and shall not interfere with any of Tenant's business operations. Landlord shall provide liability and casualty insurance at its sole expense in regard to said antenna. Tenant shall not unreasonably withhold its consent to the location of said antenna.

2. **Term.** The initial term of this Lease shall be for a period of seven (7) full years commencing the earlier to occur of December 1, 1998 or the date upon which Tenant is first obligated to pay \$55,000.00 per month rental as provided in Paragraph 4 hereof, and expiring on November 30, 2005. Subject to Landlord's Work to be performed as set forth in Exhibit C, Tenant shall be entitled to exclusive possession of the premises upon full execution and delivery of this Lease.

Tenant is hereby given the option to extend the term hereof on all the provisions contained in this Lease, except for fixed rent, which shall be determined pursuant to Paragraph 4 hereinbelow, for two (2) consecutive periods of five (5) years following expiration of the initial lease term; provided that on the date the applicable extended term is to commence Tenant shall not be in default under this Lease (after receipt by Tenant of any notice required under the terms of this Lease and beyond any cure period provided for in this Lease). To exercise the first such option to extend, Tenant shall give Landlord written notice of exercise of such option at least one (1) year prior to the expiration of the initial term. To exercise the second such option to extend, Tenant shall give Landlord written notice of exercise of such option at least one (1) year prior to the expiration of the first option term. Notwithstanding anything to the contrary contained in this Lease, if Tenant fails to give any such notice of exercise within the time provided herein, Tenant shall not be deemed to have waived the applicable option to extend unless and until Landlord shall have given Tenant written notice of such failure and such failure continues for a period of twenty (20) days after Tenant's receipt of such notice. In the event that on the date the applicable extended term is to commence Tenant shall be in default under this Lease (after receipt by Tenant of any notice required under the terms of this Lease and beyond any cure period provided for in this Lease), at Landlord's option, the extended term shall not commence and this Lease shall thereupon expire. All references in this Lease to the term shall mean the initial term, and upon the exercise of any option pursuant to this paragraph, the initial term as extended by any such options.

3. **Payment of Rent.** Tenant hereby covenants and agrees to pay to Landlord the "fixed rent" as set forth in Paragraph 4 below. The payment of rent hereinafter set forth shall begin on the first day of the month next following occupancy by Tenant of the building. Rent shall be payable to Landlord at the address set forth on page iii of this Lease, or at such other address designated by Landlord.

4. **Rent.** Tenant shall pay to Landlord annual fixed rent, payable in monthly installments in advance on the first day of each month throughout the term as set forth below. The first month's rent shall commence on the first day of the month next following occupancy by Tenant of any portion of the building and shall be calculated based upon the usable Floor Area first occupied by Tenant multiplied by \$1.43 per square foot of usable Floor Area. The rent payable on the first day of each month thereafter through and including November 30, 1998 shall also be calculated based upon the

usable Floor Area then occupied by Tenant multiplied by \$1.43 per square foot of usable Floor Area; provided, however, Tenant shall pay not less than \$27,500.00 monthly rent from and after July 15, 1998, and not less than \$55,000.00 monthly rent from and after December 1, 1998, so long as Landlord's Work shall have been completed at the time and in the manner required under the provisions of Exhibit "C" of this Lease and further provided that the Landlord's Allowance for Tenant's Work (as such terms are defined in Exhibit "C") shall have been allocated for the use of Tenant as required in said Exhibit "C".

So long as all of the provisions set forth above in this Paragraph 4 have been complied with by Landlord, Tenant shall pay \$55,000.00 monthly rent each month from and after December 1, 1998, through and including the entire initial term of this Lease, except during any option terms. Rent during the first option term shall be the sum of \$60,500.00 per month payable from and after December 1, 2005 through the expiration or termination of the first option term. Rent during the second option term, if any, shall be \$66,550.00 per month. There shall be no increases in rent during the initial term, or any option term other than as immediately set forth above.

**5. Lease Contingency.** The satisfaction of the following condition shall constitute a condition precedent to (i) the commencement of the term of this Lease (ii) Tenant's acceptance of the premises, and (iii) Tenant's obligations under this Lease: not later than ninety (90) days after Tenant submits plans and specifications to the appropriate governmental agency, Tenant shall have procured all required building, signage, conditional use and other permits, licenses and approvals necessary to enable Tenant to perform Tenant's Work, to install Tenant's desired signs, to fixturize the premises and to conduct its intended business on the premises. In the event such condition is not satisfied within the time period set forth herein, because a governmental agency has not timely approved the issuance of any such permits, licenses or approvals, Tenant shall have the right to terminate this Lease by written notice delivered to Landlord within five (5) business days after any such non-timely approval. Tenant shall diligently apply for and pursue to completion, using its best efforts, the obtaining of such approvals and shall not voluntarily withdraw its applications or not provide required information to a governmental agency. The foregoing condition shall be deemed waived by Tenant upon the acceptance by Tenant of any sums from Landlord's Allowance for Tenant's Work. If for any reason Landlord shall not deliver possession of the premises to Tenant on or before April 15, 1998, due to no act or omission of Tenant, such failure shall not affect the validity of this Lease but in such case Tenant shall not be obligated to pay rent until the first day of the month after the premises shall have been delivered to Tenant and the July 15, 1998 and December 1, 1998 dates for commencement of 50% and 100% of rent, respectively, shall be advanced on a day-for-day basis until the premises shall have been delivered to Tenant, provided, however, that if Landlord shall not have delivered possession of the premises as required herein on or before August 1, 1998, Tenant may, by notice in writing to Landlord within ten days thereafter, cancel this Lease, in which event the parties shall be discharged from all obligations hereunder. "Possession of the premises" (as used in the foregoing sentence) shall be deemed delivered to Tenant when (1) Landlord's Work is substantially completed, (2) the building utilities are ready for use in the premises, and (3) Tenant has reasonable access to the premises, and (4) Landlord



receives approval by the appropriate governmental agency for the portion of the Premises which has been substantially completed.

6. Taxes and Assessments. Tenant shall be responsible for and shall pay all real property taxes and assessments (whether special or general), rental business tax, and surcharges, including any increases thereon, levied or assessed against the premises, including, without limitation, any tax or excise on rent, or levy in any way relating to environmental protection, or any other real property tax, levy, assessment or other charge of any nature whatsoever imposed by any governmental authority and levied upon or assessed against the premises, including any such tax, fee or assessment levied or assessed in lieu of such real property taxes (all of which are herein referred to as "taxes and assessments"). For the purpose of this Paragraph, the term "rental business tax" as used herein shall include any business tax imposed upon Landlord, as an owner of real property, by the State of Nevada, or any political subdivision thereof, which is based upon or measured in whole or in part by amounts charged or received by Landlord under this Lease, provided that Tenant shall only pay the amount of such rental business tax that would be payable by Landlord if the premises were the only property of Landlord. In the event said taxes and/or assessments are not paid as required hereunder, and such failure continues for ten (10) days after Tenant's receipt of notice thereof from Landlord, Landlord may, in addition to all other remedies permitted in this Lease, pay such taxes and assessments for Tenant, bill Tenant therefor and add an additional charge equal to any penalty and interest that are then due. Such sums shall then be due and payable with the next payment of fixed rent.

Tenant shall pay in a timely manner all property taxes and assessments on the furniture, fixtures, equipment, merchandise and other property of Tenant at any time situated or installed in the premises, and in addition, on improvements in the premises made or installed by Tenant subsequent to the commencement of rent hereunder. If at any time during the term of this Lease any of the foregoing are assessed as a part of the real property of which the premises are a part, Tenant shall pay to Landlord upon demand the amount of such additional taxes as may be levied against said real property by reason thereof. For the purpose of determining said amount, figures supplied by the County Assessor as to the amount so assessed shall be conclusive.

In no event shall Tenant be required to pay (a) any portion of Landlord's general income, franchise, inheritance, estate or gift taxes, or (b) any business license tax or fee imposed against Landlord which is generally applicable to all business owners or operators in the city, county or state in which the premises are located.

Landlord shall furnish Tenant with copies of all applicable bills pertaining to taxes and assessments, until such bills are in Tenant's name and sent to Tenant.

Landlord agrees that the definition of taxes and assessments shall specifically exclude any increase in the tax bill occurring after the date of this Lease resulting from a reassessment of the premises because of a sale, assignment, or other transfer of the premises or any part thereof.

Tenant shall have the right at its expense to contest the rate, legality or validity of any tax or assessment to be paid by Tenant, but no such contest shall be carried on or maintained by Tenant after such taxes or assessments become delinquent unless Tenant shall (i) pay the amount involved under protest, or (ii) procure and maintain a stay of all proceedings to enforce collection, forfeiture and sale and provide for payment thereof together with all penalties, interest, costs and expenses by the deposit of a sufficient sum of money or by a good and sufficient undertaking or other means required or permitted by law to accomplish such stay. At the request of Tenant, Landlord will execute or join in the execution of any instrument or documents reasonably required by Tenant in connection with any such contest. Any refund obtained shall be the property of Tenant.

7. **Insurance.** At all times during the term of this Lease, Landlord shall maintain in full force and effect with insurance companies licensed to do business in the State of Nevada and otherwise satisfactory to Landlord in its reasonable discretion one or more policies including the following coverages:

A. "All risk" (as such term is customarily used and accepted in the insurance industry) property insurance on the building and parking area improvements as shown on Exhibit B, earthquake insurance at Landlord's option, loss of rental income insurance at Landlord's option, sprinkler leakage (if the building contains sprinklers) insurance in such form and with such covered perils as Landlord deems appropriate in its reasonable discretion insuring the premises in an amount equal to the full replacement value thereof. All proceeds shall belong to and be the sole property of Landlord, and Tenant hereby assigns to Landlord or its nominee all of Tenant's right, title and interest thereto.

B. Plate glass insurance covering the full replacement value of plate glass, frames and lettering thereon within and part of the building to include a safety glazing material endorsement, any deductible provisions of which are solely for the account of Landlord.

Landlord shall have the right to maintain blanket policies with the foregoing limits provided that the amount of insurance coverage is not reduced. A certificate of insurance evidencing the insurance coverage required of Landlord hereunder shall be delivered to Tenant within thirty (30) days after satisfaction or waiver of the lease contingency set forth in paragraph 5, above, and shall provide that the policy may not be cancelled or modified without at least thirty (30) days prior written notice to Tenant. The certificate shall also provide that Tenant shall receive notice of renewal of such insurance policy annually not later than ten (10) days prior to the policy's scheduled expiration date. If Tenant receives notice that the insurance required to be obtained by Landlord pursuant to this Paragraph is to be cancelled or will expire, and if prior to ten (10) days before the effective date of cancellation or expiration Tenant has not received written notice from the insurance carrier or agent that the policy will be extended or a new policy substituted in its place, then Tenant shall have the right without notice, but shall have no obligation, to procure such substitute insurance insuring the premises as Tenant in its discretion deems reasonable, and deduct such premiums from the fixed rent. Landlord agrees that all insurance policies shall contain an endorsement stipulating that Tenant, its officers,



directors, employees and agents are included as additional insureds thereon, and that such insurance shall not be cancelable without ten (10) days prior written notice to Tenant.

Beginning prior to the commencement of Tenant's Work and continuing at all times during the term of this Lease, Tenant shall maintain in full force and effect with insurance companies licensed to do business in the State of Nevada one or more policies evidencing the following coverage a certificate of which shall be submitted to Landlord prior to Tenant's undertaking Tenant's Work:

A. Comprehensive general liability insurance insuring all operations within the building and parking area, independent contractors, products and completed operations and contractual liability arising from the operation, possession, maintenance or use of the premises or areas immediately adjacent thereto with limits of liability of not less than \$2,000,000 each person, and \$5,000,000 each occurrence for bodily injury, and personal injury and \$100,000 each occurrence for property damage.

B. Comprehensive automobile liability insurance insuring all owned, nonowned and hired vehicles used in the conduct of Tenant's business and operated upon or parked upon the parking areas with limits of liability of not less than \$2,000,000 each person and \$5,000,000 each occurrence for bodily injury and \$100,000 each occurrence for property damage.

C. Standard Form Workers' Compensation and Employer's Liability Insurance covering all Tenant's employees for injury or illness suffered in the course of or arising out of their employment providing Statutory Workers Compensation benefits and Employer's Liability Limits of not less than \$100,000.

D. Fire, extended coverage, vandalism and malicious mischief, and other perils at Tenant's discretion, insurance in an amount equal to the full actual cash value of all furniture, fixtures, stock and equipment, including fixtures and improvements and betterments installed by Tenant in the premises, any deductible provisions of which are solely for the account of Tenant.

E. Business Interruption insurance covering at least sixteen (16) weeks of interruption of Tenant's business per year.

A duplicate original or certificate of all such policies shall be delivered to Landlord at least fifteen (15) days prior to the time such insurance is first required to be carried by Tenant and thereafter at least fifteen (15) days prior to the expiration or cancellation of any such policy. In the event Tenant fails at any time during the term of this Lease to obtain such insurance or to provide such evidence thereof, and such failure continues for ten (10) days after Tenant's receipt of notice thereof from Landlord, Landlord shall have the right but not the duty to procure such insurance and Tenant shall pay to Landlord the costs and expenses thereof as additional rent when the next payment of fixed rent is required to be made.

Tenant agrees that all insurance policies shall contain an endorsement stipulating that Landlord, its officers, employees and agents are included as additional insureds thereon, except Workers' Compensation Insurance, and that such insurance shall not be cancelled without thirty (30) days written notice to Landlord. All policies of insurance obtained by Tenant shall contain the following provision: "Such insurance as afforded by this policy for the benefit of Landlord shall be primary as respects any claims, losses or liabilities arising out of the use of premises by Tenant or by Tenant's assignees, sub-tenants, and permittees, and any insurance carried by Landlord shall be excess and non-contributing."

Landlord and Tenant hereby waive any rights each may have against the other on account of any loss or damage occasioned to Landlord or Tenant, as the case may be, or their respective property, the premises, or its contents, arising from any risk generally covered by all risk insurance in Nevada; and the parties each, on behalf of their respective insurance companies insuring the property of either Landlord or Tenant against any such loss, waive any right of subrogation that it may have against Landlord or Tenant, as the case may be.

Tenant agrees to pay to Landlord upon demand the amount of any increase in premiums for insurance against loss by fire that may be charged during the term of this Lease on the amount of insurance to be carried by Landlord on the premises resulting from Tenant doing any act in or about the premises which does so increase the insurance rates, whether or not the Landlord shall have consented to such act on the part of Tenant.

All policies of insurance required under this Lease shall be written by companies of generally accepted responsibility and credit, licensed to do business in Nevada. Such insurance companies shall at all times have a policyholder's rating of "B+" or better and financial rating of Class X or better as reflected in the most recent edition of "Best's Insurance Guide".

In lieu of providing individual policies of insurance, the insurance protection required of Tenant may be provided in the form of blanket policies of insurance covering the premises and other properties; provided, however, certificates of insurance evidencing the coverage required hereunder shall be provided as herein required and any such blanket policy shall provide that the amount of insurance required under this Lease shall not be prejudiced in any manner by other losses covered by the policy.

8. Utilities. Tenant agrees to pay timely all charges for gas, heat, sewer, power, electricity, telephone, storm drain, water service and water meter charges and all other utility charges (but not including any hook up or connection fees or charges) which may accrue with respect to the premises during the term of this Lease whether the same be charged or assessed at flat rates, measured by separate meters or prorated by the utility company. Landlord shall in no event be liable to Tenant for any interruption in the service of any such utilities to the premises, however such interruption may be caused, and this Lease shall continue in full force and effect despite any such interruptions, provided, however, that if such interruption is caused by any act, or non act, of Landlord and continues for five (5) consecutive business days, Tenant shall be entitled to a day-for-day rent abatement (prorated as to

the portion of the premises affected) until such utilities shall be restored.

**9. Parking Area.** Landlord grants to Tenant the exclusive right to use the parking area (as hereinafter defined) for itself, its employees, agents, customers, invitees and licensees.

As used herein, "parking area" means all areas, improvements and facilities of every kind and nature in and around the premises utilized for access and perimeter roads, truck passageways and platforms therein; parking areas, loading docks, special easement areas, landscaped areas and berms, signs and markers; and lighting and poles.

Landlord represents and warrants that the common area will at all times contain no less than two hundred fifteen (215) parking spaces which are available for Tenant's exclusive use. Landlord shall not make and shall not allow anyone to make any changes to the shape, size, location, layout, nature or extent of the parking area as such parking area exists as of the date of this Lease, including, without limitation, (i) the construction of any buildings, signs, kiosks or other structures, whether temporary or permanent, anywhere upon the parking area; or (ii) the erection of any barriers or fences or other alterations affecting parking or access in or to the parking area.

Landlord at all times during the term shall perform major repairs to the parking area. Prior to occupancy of the premises by Tenant, Landlord shall resurface and restripe the parking area. Landlord shall perform any major repairs necessary to the parking area on a prompt basis, in no event later than 30 days after notice to Landlord of the need of such major repair. A major repair shall be any repair which costs more than Two Thousand Five Hundred Dollars (\$2,500). Tenant shall be responsible for all subsequent restriping of the parking area during the initial term of the lease and for all other repairs to the parking area.

**10. Use.** Tenant shall have the right to occupy and use the premises for office, research, child care, laboratory, educational facilities, pharmacy, health care, retail and related office uses. Any other lawful use must be approved by Landlord, which approval will not unreasonably be withheld. Nothing contained in this Lease shall be deemed or construed to impose any affirmative obligation on Tenant to make any particular use of the premises, or any use thereof at all; and nothing contained in this Lease shall be deemed or construed to require Tenant to keep the premises open for the conduct of business during any particular hours, or any particular days, or at all. Landlord warrants and represents that no covenant of exclusive use or use restriction currently in effect restricts the use of the premises. Tenant shall not allow any activity to be conducted on the premises or store any material on the premises which will increase premiums for or violate the terms of any insurance policy maintained by or for the benefit of Landlord. Tenant acknowledges that neither Landlord nor its agents or employees have made any representations or warranties as to the suitability or fitness of the Premises for the conduct of Tenant's business or for any other purpose.

For purposes of this Lease, "Hazardous Materials" means any substances defined as "hazardous



*substances*" in the Comprehensive Environmental Response, Compensation and Liability Act of 1980, as amended, 42 U.S.C. §9601-9657; the Hazardous Materials Transportation Act of 1975, 49 U.S.C. §1801-1812; the Resource Conservation and Recovery Act of 1976, 42 U.S.C. §6901-6987; or any other federal, state, or local statute, law, ordinance, code, rule, regulation, order, or decree regulating, relating to, or imposing liability or standards of conduct concerning hazardous materials, waste, or substances now or at any time hereafter in effect (collectively, "*Hazardous Materials Laws*").

Tenant will not cause or permit the storage, use, generation, or disposition of any Hazardous Materials in, on, or about the Premises by Tenant, its agents, employees, or contractors. Tenant will not permit the Premises to be used or operated in a manner that may cause the Premises or the project to be contaminated by any Hazardous Materials in violation of any Hazardous Materials Laws. Tenant will immediately advise Landlord in writing of (1) any and all enforcement, cleanup, remedial, removal, or other governmental or regulatory actions instituted, completed, or threatened pursuant to any Hazardous Materials Laws relating to any Hazardous Materials affecting the Premises; and (2) all claims made or threatened by any third party against Tenant, Landlord, or the Premises relating to damage, contribution, cost recovery, compensation, loss, or injury resulting from any Hazardous Materials on or about the Premises. Without Landlord's prior written consent, Tenant will not take any remedial action or enter into any agreements or settlements in response to the presence of any Hazardous Materials in, on, or about the Premises.

Tenant will be solely responsible for and will defend, indemnify and hold Landlord, its agents, and employees harmless from and against all claims, costs, and liabilities, including attorney fees and costs, arising out of or in connection with Tenant's breach of its obligations in this Article 10. Tenant will be solely responsible for and will defend, indemnify, and hold Landlord, its agents, and employees harmless from and against any and all claims, costs, and liabilities, including attorney fees and costs, arising out of or in connection with the removal, cleanup, and restoration work and materials necessary to return the premises and any other property of whatever nature located in, on, or about the building, to their condition existing prior to the introduction of Hazardous Materials by Tenant, its agents, employees or contractors. Tenant's obligations under this Article 10 will survive the expiration or other termination of this Lease.

11. **Repairs.** Landlord warrants and shall deliver a report that confirms that at the time possession of the premises is delivered to Tenant, the shell, structure and roof of the premises shall be in a good and watertight condition, and the heating, ventilating and air conditioning and elevator systems located in the premises shall be in good working order and condition, in accord with the Landlord's Work. In addition, and without reducing Landlord's obligations under the preceding sentence, Landlord hereby assigns to Tenant all assignable warranties of materialmen, subcontractors and equipment manufacturers in effect, if any, applicable to work performed upon or materials and equipment incorporated in or installed upon the premises.

In addition, Landlord shall, at its sole expense:

(a) Perform all major repairs to the roof, including the roof membrane, structure and supports, such that water tight conditions shall be maintained at all times during the term; provided, however, Landlord shall be entitled to invoice Tenant (with backup supporting documentation), and Tenant agrees to pay said invoice within thirty (30) days after receipt thereof, once each calendar year for all such roof repairs performed by Landlord, such invoice not to exceed twenty-five hundred dollars (\$2,500.00) in any single calendar year; (SEE PAGE 10A)

(b) Perform all major repairs to the building shell (all repairs in excess of \$2,500 shall be considered major), replacements and alterations necessary or appropriate, in the reasonable judgment of Tenant, to keep the following in compliance with all laws, ordinances, rules, regulations and orders, and in good order, condition and repair:

(1) The exterior walls, interior load bearing walls, and interior roof structural columns;

(2) The foundations, floor slab and structural supports;

(3) The gutters, downspouts and roof drain system;

(4) All wiring, plumbing, pipes, conduits and other water, sewage, utility and sprinkler fixtures and equipment (including, without limitation, all connections with and components of any private sewage system serving the premises) which are located within the slab of the premises, beneath the premises or between the building and the main public utility lines;

(5) The main HVAC components, including automatic temperature controls, electrical transformers, main panel boards and electrical switch gear, and elevator systems.

(c) Landlord shall also perform all maintenance and make all repairs and replacements which result from any structural failure of the premises or which become necessary or appropriate at any time because of any act, negligence or default under this Lease of Landlord, its agents, employees, licensees or contractors.

Except as herein provided, Tenant covenants and agrees at Tenant's own cost and expense to keep the interior of the building and parking areas, and each and every part thereof, including, without limitation, all plumbing and electrical conduits, wiring, fixtures and pipes and all sewers, floors, flooring, walls, lighting, air conditioning and heating systems, ceilings and all other parts thereof in good condition and repair at all times during the term hereof and to make or perform promptly any and all maintenance or repairs (but not repairs related to the items in subparagraph (b)(1)-(5) above) or renewals or replacements which may at any time be necessary or proper to put and keep the interior of the building and parking areas in good condition and repair, and to keep the interior and parking areas and all appurtenances thereto in a good, clean, safe and wholesome condition at all times during said

provided, further, in the event Landlord provides an entirely new roof for the building (with an appropriate minimum 20 year bondable warranty) during the term hereof, then Landlord's repair obligation with respect to said new roof shall be governed by the provisions of subparagraph (b) immediately below, and in such event, the provisions of this Section 11(a) shall be void, and of no further force and effect with respect to this lease;



term. Tenant shall pay for all janitorial services for the premises. Tenant shall obtain and maintain a preventative maintenance contract with contractors licensed and qualified to service and maintain the HVAC system and elevator systems within the building, in accord with manufacturer's specifications for such equipment and systems installed within the building.

12. **Alterations.** Notwithstanding anything to the contrary contained in this Lease, Tenant may perform non-structural alterations with respect to the premises as necessary for Tenant's permitted use of the premises, without prior approval of Landlord; provided, however, Tenant agrees to comply with all requirements of local governmental ordinances regulating said alterations, including the obtaining of all required permits. All alterations shall be performed by contractors licensed in the State of Nevada to perform such work and shall be paid by Tenant. Any structural alterations desired by Tenant shall be subject to the obtaining of Landlord's consent, which shall not unreasonably be withheld. Landlord shall be notified at least ten (10) days prior to the commencement of any construction of any alterations so that Landlord may post appropriate notices of non-responsibility under Nevada law.

Any alterations to the premises which are required by reason of any present or future law, ordinance, rule, regulation or order of any governmental authority having jurisdiction over the premises shall be at the sole cost of Landlord. At the expiration or termination of the term of this Lease, all alterations to or upon the premises, except removable trade fixtures, equipment and personal property, shall be deemed to have attached to the feehold and to have become the property of Landlord.

Tenant at its expense may install in the premises such fixtures and equipment as Tenant may desire, and Tenant may from time to time remove, replace, alter or add to such fixtures and equipment. All fixtures and equipment installed by Tenant shall remain the property of Tenant and may be removed by Tenant at any time during or at the expiration of the term.

13. **Eminent Domain.** If there is any taking of or damage to all or any part of the premises or interest therein because of the exercise of the power of eminent domain, whether by condemnation proceedings or otherwise, or any transfer of any part of the premises or parking area or any interest therein made in avoidance of the exercise of the power of eminent domain (all of the foregoing being hereinafter referred to as "taking") prior to or during the term hereof, the rights and obligations of the Landlord and Tenant with respect to such taking shall be as follows:

A. If there is a taking of all of the premises, this Lease shall terminate as of the date of such taking.

B. If any portion of the premises shall be taken, or if so much of the parking area shall be taken (regardless of whether or not any part of the premises is taken) so that Tenant's use is no longer permissible under applicable zoning ordinances, then in that event Tenant shall be entitled to terminate this Lease.

If this Lease is terminated in accordance with the provisions of this Paragraph 13, such termination shall become effective as of the date physical possession of the particular portion is taken or immediate possession is ordered. The parties shall be released from all further liability hereunder. If this Lease is not terminated as provided in this Paragraph 13, Landlord shall restore the remainder of the premises so far as practicable to a complete unit of like quality, character, and condition as that which existed immediately prior to the taking.

If this Lease is not terminated as provided in this Paragraph 13, the annual fixed rent set forth in Paragraph 4A shall be reduced by the proportion which the number of square feet of usable floor area of the premises after the taking bears to the total usable floor area of the premises immediately prior to the taking.

The award or compensation in such proceedings, whether for a total or partial taking or for diminution in the value of the leasehold or for the fee, shall be apportioned pursuant to Nevada law.

**14. Damage and Destruction.** In the event the shell and structure of the building and/or parking area, or any part thereof, shall be damaged by any casualty, this Lease shall remain in full force and effect and Landlord shall repair such damage and restore such improvements to the same condition as existed prior to the casualty as rapidly as reasonably possible, provided that insurance proceeds from insurance carried by Landlord and/or Tenant are available for such repair and restoration.

In the event of any reconstruction by Landlord of the premises under this Paragraph 14, said reconstruction shall be in strict conformity with the plans and specifications and the building permit to be obtained with the City of Las Vegas. Landlord shall be responsible for repair, reconstruction or restoration of all of Landlord's Work required hereunder. Landlord shall not be responsible for the repair and restoration of Tenant's improvements or the replacement of Tenant's stock in trade, trade fixtures, furniture, furnishings and equipment.

Notwithstanding anything to the contrary contained in this Lease, in the event the premises is damaged by any casualty (i) not insured under the property insurance policy which Tenant is required to carry pursuant to this Lease, or (ii) during the last 12 months of the term, Tenant shall have the right to terminate this Lease by notice to Landlord given within thirty (30) days after the occurrence of the casualty.

In the event of damage or destruction to the premises, the fixed rent shall be abated proportionately with the degree to which Tenant's use of the premises is impaired, commencing from the date of destruction and continuing during the period of reconstruction and replacement or until the effective date of termination of this Lease, as the case may be.

Notwithstanding anything to the contrary contained in this Lease, in the event the building, or parking area, or any portion thereof, is damaged or destroyed and as a result thereof Tenant is denied

reasonable access to the premises, and is therefore unable to operate its business in the premises and in fact ceases such operation, then, whether or not the premises was damaged or destroyed, all rent shall abate from the date of the casualty until Tenant is again reasonably able to operate its business in the premises.

15. Default by Landlord. Landlord shall in no event be charged with default in the performance of any of its obligations hereunder unless and until Landlord shall have failed to perform such obligations within thirty (30) days (or such additional time as is reasonably required to correct any such defaults) after written notice by Tenant to Landlord properly specifying wherein Landlord has failed to perform any such obligation; provided, however, except as provided hereinafter in this Paragraph 15, Tenant shall not have the right to exercise any remedy provided for herein or at law unless and until Tenant shall have delivered a written notice to any lender holding a trust deed against the premises or portion thereof, whose name and address has been given to Tenant by written notice, specifying wherein Landlord has failed to correct or remedy such default, which such notice may not be delivered until after the expiration of the period set forth herein for Landlord to remedy such default and shall grant to the lender an additional equal period within which to cure such default.

Notwithstanding anything to the contrary contained in this Lease, if Landlord fails to make a repair or perform any maintenance required to be made or performed by it under the terms of this Lease, and such failure continues for a period of five (5) days after delivery of written notice to Landlord of the necessity for such repairs or maintenance or, in the case of an emergency, within such shorter period after delivery of such notice as shall be reasonable under the circumstances, Tenant may, without waiving any claim for damages or other remedy available to it, at any time thereafter make such repair or perform such maintenance for the account of Landlord. Any amount paid or any contractual liability incurred by Tenant in curing such failure shall be deemed paid or incurred for the account of Landlord, and Landlord agrees to hold Tenant harmless therefrom and reimburse Tenant upon demand therefor plus interest thereon at a rate equal to the lesser of (i) twelve percent (12%) per annum, or (ii) the maximum rate of interest permitted by law.

The liability of Landlord to Tenant for any default by Landlord under the terms of this Lease shall be limited to the lesser of (i) the interest of Landlord in the premises, or (ii) the interest Landlord would have in said premises if the same were encumbered by third party debt in an amount equal to eighty percent (80%) of the value of said premises, and Tenant agrees to look solely to such amount for recovery of any judgment from Landlord, it being intended that Landlord shall not be personally liable for any judgment or deficiency.

16. Tenant's Default. The following shall constitute a default under this Lease:

A. Tenant shall fail, neglect or refuse to pay any installment of fixed rent, additional rent or any other charge, including, without limitation, penalty charges, required to be paid by Tenant at the time and in the amount as herein provided, or pay any moneys agreed by it to be paid promptly



when and as the same shall become due and payable under the terms hereof and such default shall continue for a period of more than three (3) days after notice thereof in writing given to Tenant by Landlord.

B. Tenant shall fail, neglect or refuse to keep and perform any of the other covenants, conditions, or agreements required herein and such default shall continue for a period of more than fifteen (15) days after notice in writing given to Tenant by Landlord; provided, however, that if the cause for giving such notice involves the making of repairs or other matters reasonably requiring a longer period of time than the period of such notice, Tenant shall be deemed to have complied with such notice if Tenant has commenced to cure any such default and diligently proceeds to complete such cure.

C. Any attachment or levy of execution or similar seizure of the premises or Tenant's merchandise, fixtures or other property at the premises or any foreclosure, repossession, or sale under any chattel mortgage, security agreement or conditional sales contract covering Tenant's merchandise, fixtures or other property at the premises; or the filing of any petition by or (unless released or dismissed within 60 days) against Tenant under any chapter of the Bankruptcy Code, or the adjudication of Tenant as a bankrupt or insolvent; or the appointment of a receiver or trustee to take possession of all or substantially all of the assets of Tenant or a general assignment by Tenant for the benefit of creditors; or any other action taken or suffered by Tenant under any state or federal insolvency or bankruptcy act and the continuation thereof for more than sixty (60) days.

D. Tenant shall refuse to take possession of the premises or shall abandon the premises once Tenant has taken possession.

In the event of an act of default by Tenant, Landlord may, at its option: (1) terminate Tenant's right to possession of the premises because of such breach and recover from Tenant all damages allowed under laws of the State of Nevada, including, without limitation, the worth at the time of the award of the amount by which the unpaid rent for the balance of the term after the time of award exceeds the amount of such rental loss that Tenant proves could be reasonably avoided; or (2) not terminate Tenant's right to possession because of such breach, but continue this Lease in full force and effect; and in that event Landlord may enforce all rights and remedies under this Lease, including the right to recover the rent and all other charges due hereunder as such rent and other charges become due; or (3) declare a forfeiture of the Lease and terminate all of Tenant's rights in accordance with such forfeiture.

In the event of any reentry, Landlord may remove all persons from the premises and all property and any signs located in or about the premises and place such property in storage in a public warehouse at the cost and risk of Tenant.

Except in the case of Landlord's willful misconduct, Tenant hereby waives all claims or demands for damages that may be caused by Landlord in reentering and taking possession of the premises as hereinabove provided and all claims or demand for damages which may result from the destruction of

or injury to the premises and all claims or demands for damage or loss of property belonging to Tenant or to any other person or firm that may be in or about the premises at the time of such reentry.

Nothing contained in this Lease shall limit Landlord to the remedies set forth in this Paragraph, and upon Tenant's default Landlord shall be entitled to exercise any right or remedy then provided by law; including, but without limitation, the right to obtain injunctive relief and the right to recover all damages caused by Tenant's default in the performance of any of its obligations under this Lease.

Neither this Lease nor any interest herein nor any estate hereby shall pass by operation of law under any State or Federal insolvency or bankruptcy act to any trustee, receiver, assignee for the benefit of creditors or any other person whatsoever without the prior written consent of Landlord.

If Tenant shall fail to pay within three (3) days after receipt of notice that the same is past due and payable, any rent or additional rent or amounts or charges under this Lease is due and payable, such amounts shall bear interest at the maximum lawful rate (not to exceed 12% per annum) from the date due to the date of payment. In addition to such interest, Tenant acknowledges that the late payment by Tenant of any such amount will cause Landlord to incur certain costs and expenses not contemplated under this Lease, the exact amount of which costs being extremely difficult or impractical to fix. Such costs and expenses will include, without limitation, administrative and collection costs, and processing and accounting expenses. Therefore, if any such payment is not received by Landlord within three (3) days after receipt of notice that the same is past due, Tenant shall immediately pay to Landlord a late charge equal to five percent (5%) of the overdue amount. Landlord and Tenant agree that this late charge represents a reasonable sum considering all of the circumstances existing on the date of this Lease, including the relationship of the sum to the loss to Landlord that could reasonably be anticipated by such non-payment by Tenant, and the anticipation that proof of actual damages would be costly or inconvenient to determine. Acceptance of such late charge shall not constitute a waiver of Tenant's default with respect to such non-payment by Tenant nor shall it prevent Landlord from exercising all other rights and remedies available to Landlord under this Lease.

If the Tenant becomes a debtor under Chapter 7 of the United States Bankruptcy Code (the "*Bankruptcy Code*"), or in the event that a petition for reorganization or adjustment of debts is filed concerning the Tenant under Chapter 11 or Chapter 13 of the Bankruptcy Code, or a proceeding filed under Chapter 7 is transferred to Chapter 11 or 13, the "*Trustee*" or the Tenant, as "*Debtor-in-Possession*," shall be deemed to have rejected this Lease. No election by the Trustee or Debtor-in-Possession to assume this Lease shall be effective unless each of the following conditions, which Landlord and Tenant hereby acknowledge to be commercially reasonable in the context of a bankruptcy proceeding, has been satisfied, and the Landlord has so acknowledged in writing: (i) the Trustee or Debtor-in-Possession has cured, or has provided the Landlord "*adequate assurance*" (as hereinafter defined) that from the date of such assumption the Trustee or Debtor-In-Possession will promptly cure, all monetary and non-monetary defaults under the Lease; (ii) the Trustee or Debtor-in-Possession has compensated, or has provided to the Landlord adequate assurance that within ten (10) days of the date

of assumption the Landlord will be compensated, for any pecuniary loss incurred by the Landlord arising from default of the Tenant, the Trustee, or the Debtor-in-Possession as recited in the Landlord's written statement of pecuniary loss sent to the Trustee or Debtor-in-Possession; and (iii) the Trustee or Debtor-in-Possession has provided the Landlord with adequate assurance of future performance of each of the Tenant's, the Trustee's, or the Debtor-in-Possession's obligations under this Lease; provided, however, that: (x) the Trustee or Debtor-in-Possession shall also deposit with the Landlord, as security for the timely payment of rent and other sums due hereunder, an amount equal to three months Base Rent, Additional Rent, and other monetary charges accruing under this Lease; and (y) the obligations imposed upon the Trustee or Debtor-in-Possession shall continue with respect to the Tenant or any assignee of this Lease after the completion of the bankruptcy proceedings.

*Adequate Assurance.* For purposes of this Lease, Landlord and Tenant acknowledge that, in the context of the bankruptcy proceedings of the Tenant, at a minimum, "adequate assurance" shall mean: (i) the Trustee or Debtor-in-Possession will continue to have sufficient unencumbered assets after the payment of all secured obligations and administrative expenses to assure the Landlord that the Trustee or Debtor-in-Possession will have sufficient funds to fulfill all of the obligations of Tenant under this Lease; or (ii) the Bankruptcy Court shall have entered an order segregating sufficient cash payable to the Landlord, and the Trustee or Debtor-in-Possession shall have granted to the Landlord a valid and perfected first lien and security interest or mortgage in property of the Tenant, the Trustee, or the Debtor-in-Possession, acceptable as to value and kind to the Landlord, in order to secure to the Landlord the obligation of the Tenant, Trustee, or Debtor-in-Possession to cure the monetary or non-monetary defaults under the Lease within the time period set forth above.

*Lease Assignments in Bankruptcy Proceedings.* The following conditions shall apply to any assignments of this Lease in bankruptcy proceedings if the Trustee or Debtor-in-Possession has assumed this Lease and elects to assign the Lease to any other person, such interest or estate of Tenant in this Lease may be so assigned only if the Landlord has acknowledged in writing that the intended assignee can provide to the Landlord "adequate assurance of future performance" (as herein defined) of all of the terms, covenants and conditions of this Lease to be performed by the Tenant. For the purposes of this provision, Landlord and Tenant acknowledge that, in the context of a bankruptcy proceeding, at a minimum, "adequate assurance of future performance" shall mean that each of the following conditions has been satisfied, and the Landlord has so acknowledged in writing: (i) the proposed assignee has submitted a current financial statement audited by a Certified Public Accountant which shows the net worth and working capital and amounts determined by Landlord to be sufficient to assure the future performance by such assignee of all of Tenant's obligations under this Lease; (ii) the proposed assignee, if requested by the Landlord, has obtained guarantys in form and substance satisfactory to the Landlord from one or more persons who satisfy the Landlord's standards of creditworthiness; and (iii) the Landlord has obtained all consents or waivers from any third party required under any lease, mortgage, financing arrangement, or other agreement by which the Landlord is bound, in order to permit the Landlord to consent to such assignment.



**17. Indemnification, Release and Liens.** Except as otherwise provided in this Lease, Tenant agrees that Landlord shall not be liable, responsible, or in any way accountable, to Tenant, Tenant's agents, employees, servants, customers or invitees, or to any person whomever, for any loss, theft or destruction of or damage (including, but not limited to, any damage caused by rain, storm or other water damage) to any goods, wares, merchandise, fixtures or other property stored, kept, maintained, on or about the premises, or in, on or about the facilities, the use of which Tenant may have in conjunction with this Lease, nor for injury to or death of any person or persons who may at any time be using, occupying or visiting the premises.

Except to the extent contributed to by the gross negligence or willful misconduct of Landlord, its agents, employees or contractors, Tenant shall indemnify, defend and hold harmless Landlord, its agents and employees from and against any and all damages, claims, losses, liabilities, costs and expenses (including, without limitation, reasonable attorneys' fees), for damage to or loss of property (including Tenant's property) or injury to or death of persons (including Tenant, its agents, employees, visitors, or invitees) directly or indirectly resulting from anything occurring from any cause on or about the premises, in connection with the maintenance or operation of Tenant's business, or Tenant's occupation or use of the premises. Tenant shall discharge any judgment or compromise rendered against or suffered by Landlord as a result of anything indemnified against hereunder and shall reimburse Landlord for any and all costs, fees or expenses incurred or paid by Landlord (including, without limitation, reasonable attorneys' fees) in connection with the defense of any such action or claim.

Except to the extent contributed to by the gross negligence or willful misconduct of Tenant, its agents, employees or contractors, Landlord shall indemnify, defend and hold Tenant harmless from and against any and all damages, claims, losses, liabilities, costs and expenses (including, without limitation, reasonable attorneys' fees) due to claims of third persons arising from or in connection with Landlord's ownership, management, repair, maintenance or reconstruction of the building or any part thereof, or any act, omission, fault or negligence of Landlord or Landlord's agents, contractors or employees or any failure on Landlord's part or the part of Landlord's agents, contractors or employees to comply with any of the terms, covenants and conditions contained in this Lease.

To the extent arising out of work or materials provided by or on behalf of Tenant, Tenant shall keep the premises and all of the right, title and interest of Tenant and Landlord therein free and clear of all liens or claims which may ripen into such a lien or encumbrance, and in the event Tenant fails to do so, Landlord may pay such lien or encumbrance or claim, and on or before the tenth (10th) day of the month following the month during which such payment is made, Tenant shall pay to Landlord such sums so paid, plus such reasonable costs and attorneys' fees as may have been incurred by Landlord; provided, however, that in the event Tenant in good faith disputes such lien or encumbrance and with reasonable promptness furnishes an indemnity bond or such undertaking in an amount sufficient either to procure the release of such lien or encumbrance or to indemnify against the principal amounts thereof, together with such costs or attorneys' fees as may be covered by said lien or encumbrance, then

the furnishing of such bond or undertaking shall be deemed due compliance with the foregoing provision.

**18. Non-Disturbance, Subordination and Financing.** This Lease is and shall be junior to the financing to be obtained by Landlord prior to the performance of Landlord's Work hereunder (the "Initial Deed of Trust"). This Lease is and shall be prior to any subsequent deed of trust affecting all or any part of the premises. If, however, the holder of any such subsequent deed of trust requires that this Lease be subordinated to such deed of trust, Tenant agrees to subordinate this Lease to that deed of trust if Landlord first obtains from such holder a written nondisturbance agreement in form and substance similar to Exhibit "E-1" attached hereto. In no event shall Tenant's obligations be increased or Tenant's rights decreased by such nondisturbance agreement. Such nondisturbance agreement shall be recorded in the office of the county recorder of the county in which the premises are located. The terms "Initial Deed of Trust" and "deed of trust" as used herein include mortgages, deeds of trust, other monetary liens or encumbrances, all modifications, extensions, renewals and replacements thereof, given as collateral security for any obligation affecting the premises.

Tenant shall receive from the lender under the Initial Deed of Trust, and from the Ground Lessor under the Ground Lease, a Nondisturbance and attornment agreement substantially in the form attached hereto as Exhibit "E-1" and "E-2", respectively, within forty-five (45) days after the date of this Lease.

Upon payment by Tenant of all of the rents herein provided, and upon the observation and performance of all of the covenants, terms and conditions on Tenant's part to be observed and performed, Tenant shall quietly hold and enjoy the premises for the term hereby leased without hindrance or interruption by Landlord or any other person or persons lawfully or equitably claiming by, through or under Landlord, subject nevertheless to the terms and conditions of this Lease.

At any time and from time to time, upon request in writing from either party, the other party agrees to execute, acknowledge and deliver to the requesting party a statement in writing certifying that this Lease is unmodified and in full force and effect (or if there have been modifications that the same

is in full force and effect as modified and stating the modifications), the dates to which fixed rent, and other charges have been paid, the expiration date of the term and any other matters regarding this Lease as reasonably requested. It is understood and agreed that any such statement may be relied upon by any prospective purchaser of the leasehold or the mortgagee, beneficiary or grantee of any security or interest, or any assignee of any thereof, under any mortgage or deed of trust now or hereafter made covering any leasehold interest in the premises or the real property covered by this Lease, or any assignee, subtenant or successor of Tenant.

In the event any proceedings are brought for foreclosure, or in the event of the exercise of the power of sale under any mortgage or deed of trust made by the Landlord covering the premises or should the Lease in which Landlord is the tenant be terminated, the Tenant shall attorn to the purchaser

or landlord under said Lease upon any such foreclosure, sale or lease termination and recognize such purchaser or landlord as the Landlord under this Lease and the purchaser or lessor shall acquire and accept the premises subject to this Lease.

Landlord and Tenant shall each execute and deliver to the other the appropriate documents required hereunder not later than twenty (20) days from receipt of written request therefor.

If, during the term of this Lease, Landlord sells its interest in the premises, or this Lease, or all or any portion of the building, then all rights and obligations of Tenant hereunder shall remain in full force and effect as though there had been no such sale or transfer. Upon such transfer and conveyance, Landlord shall be unconditionally released of all obligations of Landlord thereafter accruing hereunder from the date of such sale or transfer.

This Lease shall not be recorded without the prior written consent of Landlord; provided, however, if either party so requests, Landlord and Tenant agree to execute and deliver a short form or memorandum of this Lease for recordation.

**19. Surrender of Premises.** At the expiration of the term of this Lease, Tenant shall surrender to Landlord the premises in good order and condition, reasonable wear and tear, Landlord's obligations and casualty damage excepted, and shall surrender all keys for the premises to Landlord at the place then fixed for the payment of rent and shall inform Landlord of all combinations on locks, safes and vaults, if any, in the premises. No act or conduct of Landlord, except a written acknowledgment of acceptance of surrender signed by Landlord, shall be deemed to be or constitute an acceptance of the surrender of the premises by Tenant prior to the expiration of the term of this Lease.

If, prior to the termination of this Lease or within fifteen (15) days thereafter, Landlord elects by written notice to Tenant, Tenant shall promptly remove the trade fixtures, signs and personal property which were placed in the premises by Tenant and which are designated in said notice and shall repair any damage occasioned by such removal; and in default thereof Landlord may effect said removals and repairs at Tenant's expense. The covenants of Tenant contained herein shall survive the expiration or termination of the term.

**20. Construction of Premises; Cooperation.** At no cost to Tenant, Landlord shall assist and cooperate with Tenant in Tenant's efforts to obtain approval of Tenant's plans, if any, by all appropriate governmental agencies. In the event that prior to or during the construction of any work or improvements prior to the commencement of rent, any asbestos or asbestos containing material (collectively, "ACM") is found in the premises, the commencement of rent shall be extended by the number of days Tenant's Work is delayed solely by virtue of any work in connection with the removal of such ACM.

**21. Notices.** Whenever under this Lease a provision is made for any notice, request, demand



or other communication (collectively, "notice") to a party it shall be in writing delivered personally, by certified mail, return receipt requested, with postage prepaid, or by recognized overnight courier service providing a receipt for delivery, addressed to Tenant or to Landlord at the address on page (iii) of this Lease. Either party may by like notice at any time and from time to time designate a different address to which or a different person to whom or in care of whom notices shall be sent. Notices which are mailed or sent by overnight courier shall be deemed delivered upon actual receipt or attempted delivery as shown in the return receipt.

22. **Attorneys' Fees.** In case suit shall be brought for any breach of this Lease, the prevailing party shall be entitled to reasonable attorneys' fees, at trial or on appeal, which shall be fixed by the Court or in any compromise or settlement. Such attorneys' fees shall be deemed to have accrued on the commencement of such action and shall be paid whether or not such action is prosecuted to judgment. If either party shall employ the services of any attorney(s) by reason of any default or failure of timely performance by the other party and suit is not brought thereon, the defaulting party shall pay to the other party all attorneys fees so incurred.

23. **Assignment and Subletting.** Tenant shall be permitted to assign this Lease, or any interest therein, and to sublet the premises or any part thereof, and be allowed to permit any other person to occupy or use the premises, or any portion thereof, without first obtaining the consent of Landlord, for any of the uses permitted in this Lease. No assignment or sublease shall release the Tenant from liability for the continued performance of the terms and provisions on the part of Tenant to be kept and performed, unless Landlord specifically releases the Tenant from said liability. No other assignment or subletting shall be permitted without Landlord's consent, which shall not unreasonably be withheld.

In the event of default by any assignee of Tenant or any successor of Tenant in the performance of any of the terms hereof, Landlord may proceed directly against Tenant without the necessity of exhausting remedies against such assignee or successor.

24. **Access.** Upon 24 hours prior written notice to Tenant, Landlord and its agents shall have reasonable access to the premises during all reasonable hours for the purpose of examining the same and to ascertain if Tenant is in compliance with the terms of this Lease, to exhibit the same to prospective purchasers or tenants and to post notices of nonresponsibility in reasonable locations and at reasonable times. During any entry into the premises Landlord shall use its best efforts to minimize interference with Tenant's business operations.

25. **Holdover.** In the event the Tenant shall hold over the premises after the expiration of the term hereof with the consent of the Landlord either express or implied, such holding over shall be construed to be only a tenancy from month-to-month, subject to all the covenants, conditions and obligations hereof and the Tenant hereby agrees to pay the Landlord the same rentals, plus ten percent (10%), provided for by this Lease for such additional times as Tenant shall hold such property.

26. Insolvency of Tenant. Tenant agrees that in the event all or substantially all of its assets be placed in the hands of a receiver or trustee, and in the event such receivership or trusteeship continues for a period of thirty (30) days, or should Tenant make an assignment for the benefit of creditors, or be adjudicated a bankrupt, or should Tenant institute any proceedings under any state or federal bankruptcy act wherein Tenant seeks to be adjudicated a bankrupt or seeks to be discharged of its debts, or should any voluntary proceeding be filed against such Tenant under such bankruptcy laws and Tenant consents thereto or acquiesces therein by pleading or default, then this Lease or any interest in and to the premises shall not become an asset in any of such proceedings and, in any of such events and in addition to any and all rights or remedies of Landlord hereunder or as provided by law, it shall be lawful for Landlord at its option to declare the term hereof ended and to reenter the premises and take possession thereof and remove all persons therefrom and Tenant shall have no further claim therein or hereunder.

27. Surrender of Lease. The voluntary or other surrender of this Lease by Tenant, or a mutual cancellation thereof, shall not work a merger, and shall, at the option of Landlord, terminate all or any existing subleases or subtenancies, or may, at the option of Landlord, operate as an assignment to it of any or all of such subleases or subtenancies.

28. Sale of Premises by Landlord. In the event of any sale of the premises by Landlord, Landlord shall be and is hereby entirely freed and relieved of all liability under any and all of its covenants and obligations contained in or derived from this Lease arising out of any act, occurrence or omission occurring after the consummation of such sale; and the purchaser, at such sale or any subsequent sale of the premises shall be deemed, without any further agreement between the parties or their successors in interest or between the parties and any such purchaser, to have assumed and agreed to carry out any and all of the covenants and obligations of the Landlord under this Lease.

29. Signs. Tenant may install and maintain upon the premises, including the front, sides and rear exterior parapet walls, such building identification signs advertising the business conducted on the premises by Tenant as are permitted by applicable law. All building signs installed by Tenant shall comply with all applicable laws, rules and ordinances of state or local governmental authorities, shall remain the property of Tenant, and may be removed by Tenant at the termination of this Lease.

30. Miscellaneous.

A. The laws of the State of Nevada shall govern the validity, construction, performance and enforcement of this Lease.

B. The unenforceability or invalidity of any one or more provisions hereof shall not render any other provisions herein contained unenforceable or invalid.

C. As used in this Lease and whenever required by the context thereof, each number,

both singular or plural, shall include all numbers, and each gender shall include all genders. Landlord and Tenant as used in this Lease or in any other instrument referred to in or made a part of this Lease shall likewise include both the singular and the plural, a corporation, co-partnership, individual or person acting in any fiduciary capacity as executor, administrator, trustee, or in any other representative capacity. All covenants herein contained shall be joint and several.

D. The paragraph titles herein are for convenience only and do not define, limit or construe the contents of such paragraphs.

E. One or more waivers of any covenant, term or condition of this Lease by either party shall not be construed by the other party as a waiver of a subsequent breach of the same or any other covenant, term or condition. The consent or approval of either party to or of any act by the other party of a nature requiring consent or approval shall not be deemed to waive or render unnecessary consent to or approval of any subsequent act.

F. All of the terms hereof shall apply to, run in favor of and shall be binding upon and inure to the benefit of, as the case may require, the parties hereto, and also their respective heirs, executors, administrators, personal representatives and assigns and successors in interest.

G. IT IS UNDERSTOOD THAT THERE ARE NO ORAL AGREEMENTS BETWEEN THE PARTIES AFFECTING THIS LEASE AND THIS LEASE SUPERSEDES AND CANCELS ANY AND ALL PREVIOUS NEGOTIATIONS, ARRANGEMENTS, BROCHURES, AGREEMENTS, REPRESENTATIONS AND UNDERSTANDINGS, IF ANY, BETWEEN THE PARTIES HERETO OR DISPLAYED BY LANDLORD TO TENANT WITH RESPECT TO THE SUBJECT MATTER THEREOF AND NONE SHALL BE USED TO INTERPRET OR CONSTRUE THIS LEASE. FURTHERMORE, THE PARTIES EXPRESSLY AGREE THAT THIS LEASE AND THE AGREEMENTS CONTAINED HEREIN SHALL ONLY BE AMENDED OR MODIFIED BY AN AGREEMENT IN WRITING SIGNED BY BOTH LANDLORD AND TENANT AND ABSENT ANY SUCH WRITTEN AGREEMENT THIS LEASE ALONE SHALL CONSTITUTE THE ENTIRE AGREEMENT (PAST, PRESENT AND FUTURE) BETWEEN THE PARTIES.

H. Each individual signing on behalf of a party hereto represents and warrants that he or she is authorized by the Board of Directors, managing partner or other appropriate body or individual, as the case may be, to execute this Lease on behalf of such party.

I. Any prevention, delay or stoppage due to strikes, lockouts, labor disputes, acts of God, inability to obtain labor or materials or reasonable substitutes therefor, governmental restrictions, governmental regulations, governmental controls, judicial orders, enemy or hostile governmental action, civil commotion, fire or other casualty, and other causes beyond the reasonable control of the party obligated to perform, shall excuse the performance by such party for a period equal to any such



prevention, delay or stoppage. In the event Tenant encounters any of the foregoing prior to the commencement date, the commencement date shall be postponed by a period equal to the length of any such prevention, delay or stoppage, but in no event shall the commencement date be postponed to a date later than the date Tenant initially opens the premises for business to the public.

J. Except as expressly otherwise herein provided, time is of the essence of this Lease and all obligations of the parties hereto.

K. Landlord and Tenant hereby waive trial by jury in any action, proceeding, or counterclaim brought by either of the parties to this Lease against the other on any matters whatsoever arising out of or in any way connected with this Lease, the relationship of Landlord and Tenant, Tenant's use or occupancy of the premises, or any other claims (except claims for personal injury or property damage), and any emergency or other statutory remedy.

LANDLORD:

TENANT:

V.A. CLINIC ASSOCIATES,  
a Nevada limited Partnership

UNIVERSITY OF NEVADA SCHOOL OF MEDICINE  
MULTI-SPECIALTY GROUP PRACTICE SOUTH, INC.,  
a Nevada corporation

  
Mark L. Fine, General Partner

  
By: David V. Schapira, M.D., President

APPROVED:  
University of Nevada School of Medicine  
Integrated Clinical Services, Inc.,  
a Nevada corporation

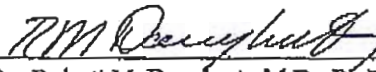
  
By: Robert M. Daugherty M.D., Ph.D., President

Leases. In such event, all of Tenant's interest under the Sub-Leases shall be deemed automatically assigned, transferred and conveyed to Landlord. Landlord shall thereafter be bound on the Sub-Leases to the same extent Tenant was so bound and shall have all the rights that Tenant has under the Sub-Leases, including the right to collect rents from Sub-Tenants under the Sub-Leases and the right to terminate the Sub-Leases upon default by Sub-Tenants.

4. *Successors and Assigns.* This Agreement shall be binding on and shall inure to the benefit of the parties hereto and their successors and assigns.

IN WITNESS WHEREOF, the parties hereto have executed this Agreement as of the day and year first above written.

**LANDLORD:**

**SUB-TENANT:**

UNIVERSITY OF NEVADA SCHOOL OF  
MEDICINE MULTI-SPECIALTY GROUP  
PRACTICE SOUTH, INC.

By: \_\_\_\_\_  
SANDRA BUSHROB

By: \_\_\_\_\_  
LINDA MAY ZOELLER

By: \_\_\_\_\_  
Its: \_\_\_\_\_

**TENANT:**

**APPROVED:**

V.A. CLINIC ASSOCIATES,  
a Nevada limited partnership

University of Nevada School of Medicine  
Integrated Clinical Services, Inc.,  
a Nevada corporation

By: \_\_\_\_\_

By: \_\_\_\_\_  
Robert M. Daugherty, M.D., Ph.D., President



## VA CLINIC ASSOCIATES

## LEASE SUMMARY

1. Landlord: VA Clinic Associates
2. Tenant: University of Nevada School of Medicine  
Multi-Specialty Group Practice South, Inc.
3. Guarantor: N/A
4. Premises: 1703 W. Charleston Blvd., Las Vegas, NV 89102
5. Rentable Square Feet: 44,824
6. Usable Square Feet: 38,377
7. Commencement Date: 90 days after delivery of space substantially  
complete, but not later than July 15, 1998
8. Expiration Date: December 1, 2005
9. Term: Seven (7) years
10. Rent Commencement Date: August 1, 1998
11. Initial Base Rent (Annual): \$660,000
12. Initial Base Rent: \$1.43 per net rentable square feet or \$55,000 per  
month
13. Increase in Base rent: None during initial 7 year lease
14. Security Deposit: None
15. Tenant's Pro Rata Share  
of the Building: Entire building
16. Broker: Mark Fine & Associates
17. Option to Renew: Two (2) five year options



EXHIBIT A

LEGAL DESCRIPTION OF LAND

Lot 3 of Ellis Estates, as shown by map thereof on file in Book 2 of Plats, Page 61, in the Office of the County Recorder of Clark County, Nevada, excepting therefrom the South 87 feet thereof.

LEGAL DESCRIPTION OF APPROXIMATE 1/2 ACRE GROUND LEASED PARCEL

Parcel No 3-66 202, further known as 1119 Shadow Lane, as shown on Tax Assessor Plat of the Tax Assessor, Las Vegas, Nevada.

Handwritten initials and a circular stamp reading "PLEASE INITIAL".



**EXHIBIT C**  
**PROVISIONS REGARDING**

**LANDLORD'S WORK AND TENANT'S WORK AND**  
**LANDLORD'S CONSTRUCTION ALLOWANCE**

A. Landlord's Work. Within thirty days after the date of this Lease, but in no event later than January 15, 1998, Landlord shall deliver to Tenant a complete and final set of Landlord approved architectural and engineering plans and outline specifications respecting the construction work necessary to bring the premises to Class "A" office building standards within the County of Clark. Said plans shall fully describe the following works of improvement, including without limitation, the two lane driveway on Shadow Lane which has been approved by the City of Las Vegas, the building shell and facade, roof, HVAC and elevator systems, building entrances, common passageways, restrooms, common waiting areas, building mechanical systems, the manner in which utility connections shall be integrated into, and provide for connection to, the building, asbestos removal, landscaping, parking layout, including all striping, berms, poles, signs and any other improvements necessary to bring the premises to the Class "A" standard ("Landlord's Plans and Specifications").

Landlord's Plans and Specifications shall be prepared in compliance with all city, county, state and federal ordinances, rules and regulations related thereto and stamped by Landlord's architects and engineers fully qualified and licensed to prepare the drawings required herein, which shall be fully detailed and dimensioned and prepared at Landlord's expense. Within ten (10) working days after receipt of Landlord's Plans and Specifications, Tenant shall deliver to Landlord any and all changes which Tenant deems necessary or desirable. Landlord shall have ten (10) working days thereafter to resubmit Landlord's Plans and Specifications to Tenant for approval. Thereafter, Tenant shall have five (5) working days to deliver to Landlord its approval of Landlord's Plans and Specifications and/or any required further modifications.

On or before January 15, 1998, Landlord will apply for appropriate permits and commence and thereafter complete at its expense, the construction work necessary to comply with the final Landlord's Plans and Specifications approval by Tenant ("Landlord's Work"). Landlord agrees to complete Landlord's Work no later than May 1, 1998.

Landlord's Work shall include, but shall not be limited to, the following:

- (a) Exterior facade including new entrances and (6) new windows at north (front) entrance.
- (b) New windows on 1st floor east and south side (Plastic Surgery) and modification to rear

LM  



entrance to convert "Receiving" to "Plastic Surgery" in accordance with agreed upon drawing dated December 31, 1997.

- (c) Paint entire exterior of building.
- (d) Provide new exterior landscaping and lighting.
- (e) New interior lobby and atrium.
- (f) Modify north stairwell by rotating 90 degrees.
- (g) Upgrade elevator cabs.
- (h) Monumentation for signage.
- (i) Replace or restore roof in accordance to recommendations provided by a certified and licensed roofing contractor or consultant as agreed upon by Tenant.
- (j) Remove all hazardous materials (including asbestos) in all areas and the existing Halon system.
- (k) Replace or repair or add all equipment necessary to provide adequate and dependable electrical service, including transformers, main switchgear and panelboards as agreed upon by Tenant to provide a "Class A" building.
- (l) Replace or repair or add all equipment necessary to provide adequate and dependable HVAC service, and related electrical equipment as agreed upon by Tenant to provide a so-called "Class A" building. Automatic temperature control equipment for building to be provided and installed by Tenant.
- (m) Replace, repair or add all equipment necessary to provide adequate and dependable plumbing services to the building, including without limitation, hot and cold domestic water, sanitary sewage, fire sprinklers and lawn irrigation as agreed upon by Tenant to provide a "Class A" building.
- (n) All work shown on the following drawings or required by all applicable codes, including all drawings submitted for Landlord's work and signed, dated and approved by the facilities manager for Tenant:

- (1) Architectural;
- (2) Landscaping;
- (3) Mechanical;
- (4) Electrical;
- (5) Plumbing; and
- (6) Structural.

From the commencement until the completion of Landlord's Work, Landlord shall obtain and maintain, at Landlord's expense, public liability and worker's compensation insurance in an amount sufficient to fully protect Tenant and Landlord from and against liability for death or injury to persons and for damage to property caused by or arising from the performance of Landlord's Work. Tenant shall obtain and maintain, at Tenant's expense, the same insurance during all periods in which Tenant is constructing Tenant's Work as provided in this Exhibit C.

B. Tenant's Work. On or about May 1, 1998, or such earlier date as Landlord's Work shall



either (a) have been completed and Landlord shall deliver the premises to Tenant, or (b) Landlord and Tenant agree that Tenant's contractor may commence Tenant's Work during the performance of Landlord's Work, Tenant will commence and thereafter complete Tenant's Work. Tenant's Work shall be in accordance with Tenant's plans and specifications, to be prepared at the expense and discretion of the Tenant and not subject to Landlord's approval as to quality, design, cost or for any other reason whatsoever, but subject to (i) the obtaining of all required permits for Tenant's Work, (ii) Tenant's Work being performed by contractors licensed to perform such work; and (iii) such reasonable reviews and approvals as may be required by Landlord's lender, consistent with lending and construction control practices in Clark County, Nevada.

Tenant's Work shall include, without limitation, the following:

- (a) Architectural space planning;
- (b) Signage;
- (c) Phones and data lines;
- (d) All improvements within the Premises, except major electrical and mechanical upgrades, structural revisions, revisions to the building envelope (windows, exterior doors, roof penetrations, roof, etc.), which shall be at Landlord's sole cost and expense.

Tenant shall deliver an original Certificate of Occupancy, if applicable, or final inspection release to Landlord after completion of Tenant's Work or Tenant's opening for business. Tenant shall obtain and record a Notice of Completion promptly following completion of Tenant's Work and shall promptly forward a certified copy thereof to Landlord.

**C. Landlord's Construction Allowance.** Within 45 days after the date of this Lease, Landlord shall deliver to Tenant documentation sufficient to assure Tenant that the sum of One Million Eight Hundred Thousand Dollars (\$1,800,000), has been allocated by Landlord or Landlord's lender for the use of Tenant to pay construction costs for Tenant's Work and other costs in connection with Tenant's use of the premises. It is understood and agreed by both Landlord and Tenant that the entire \$1,800,000 will be fully drawn from this fund by Tenant during the construction of Tenant's Work, but in no event later than December 1, 1998. The Landlord's Construction Allowance shall be held and distributed in accordance with a standard construction control account, with appropriate progress payments, verification procedures and retentions as are customary in Clark County, Nevada. A portion of the Landlord's Construction Allowance may be provided by Landlord in the form of a donation to the University of Nevada School of Medicine, in such form as may qualify for a charitable donation under applicable tax laws and regulations.

**D.** Landlord shall be responsible for any alterations, modifications or improvements as part of Landlord's Work which are required under Title III of the Americans With Disabilities Act ("ADA").

**E.** Tenant shall be responsible for any alterations, modifications or improvements as part of



Tenant's Work which are required under Title III of the ADA. In addition, once Tenant's Work has been completed, Tenant, at Tenant's sole cost and expense, shall be responsible for any alterations, modifications or improvements to the premises, and the acquisitions of any auxiliary aids, required under the ADA, including all alterations, modifications, or improvements required: (i) as a result of Tenant (or any subtenant, assignee, or concessionaire) being a "Public Accommodation" (as defined in the ADA); (ii) as a result of the premises being a "Commercial Facility" (as defined in the ADA); (iii) as a result of any leasehold improvements made to the premises by, or on behalf of, Tenant or any subtenant, assignee, or concessionaire (whether or not Landlord's consent to such leasehold improvements was obtained or required); or (iv) as a result of the employment by Tenant (or any subtenant, assignee, or concessionaire) of any individual with a disability.

F. Credit Against Landlord's Contribution Allowance. Landlord and Tenant have agreed that Landlord's Contribution Allowance includes the sum of \$248,000 for HVAC/automatic air temperature controls and new rooftop HVAC units (collectively, the "HVAC") which Tenant will perform as part of Tenant's Work. If, at the completion of Tenant's Work, Tenant has expended less than \$248,000 for the HVAC, Tenant agrees to provide Landlord with a credit (the "Credit") against Landlord's Contribution Allowance equal to the difference between \$248,000 and the amount actually expended for the HVAC; provided, however, the Credit shall not, in any event, be more than \$88,000. For example, if Tenant expends \$240,000 for the HVAC, the Credit shall be \$8,000 (\$248,000 - \$240,000). If Tenant expends \$150,000, the Credit shall be \$88,000 (\$248,000 - \$150,000, capped at \$88,000).



EXHIBIT D

V.A. CLINIC ASSOCIATES

ESTOPPEL CERTIFICATE

With reference to that certain lease (the "Lease") dated \_\_\_\_\_, 1997, between V.A. CLINIC ASSOCIATES, a Nevada limited partnership ("Landlord"), and UNIVERSITY OF NEVADA SCHOOL OF MEDICINE MULTI-SPECIALTY GROUP PRACTICE SOUTH, INC., a Nevada corporation ("Tenant"), you are hereby notified of the following. All capitalized terms not otherwise defined herein shall have the same meaning as set forth in the Lease.

The undersigned Tenant certifies as follows to Landlord, its actual and prospective assignees and lenders, and all actual and prospective purchasers of the Building (each of whom is irrevocably entitled to rely on this Estoppel Certificate):

1. A true, correct, and complete copy of the Lease (including all riders, attachments, amendments, and/or exhibits thereto) is attached to this instrument as Attachment I and represents the entire agreement between the Landlord and Tenant relating to the Premises. There are no oral or other written agreements between Landlord and Tenant relating to the Premises or the transaction contemplated by the Lease.

2. Tenant has accepted possession of the Demised Premises under the lease, and the term of the Lease commenced on \_\_\_\_\_, 19\_\_ and will expire on \_\_\_\_\_, \_\_\_\_.

3. By the terms of the Lease, Tenant is presently obligated to pay, without present right of defense or offset, monthly base rent of \$\_\_\_\_\_. Additionally, Tenant is to reimburse Landlord for \_\_\_\_\_ Tenant has no claim against Landlord for any rent paid more than thirty (30) days in advance or any deposits or other sums other than \_\_\_\_\_.

4. Any improvements contemplated by the Lease have been contemplated in their entirety in accordance with the terms of the Lease, except for \_\_\_\_\_.

5. The address for notice to Tenant under the Lease is correct as of the date hereof.

6. Tenant has no right of first refusal, option, or other right to purchase the Premises or any part thereof, including, without limitation, the Premises.

Handwritten initials and a circular stamp containing the text "PLEASE INITIAL".

7. The execution of the Lease was duly authorized by Tenant, is in full force and effect, and is valid, binding, and enforceable against Tenant in accordance with its terms. There exists no default, nor state of facts which with notice, the passage of time, or both, could mature into a default on the part of either Tenant or Landlord.

8. There has not been filed by or against nor, to Tenant's best knowledge and belief, is there threatened against or contemplated by Tenant, a petition in bankruptcy, voluntary or otherwise, any assignment for the benefit of creditors, any petition seeking reorganization or arrangement under the bankruptcy laws of the United State or any state thereof, or any other action brought under said bankruptcy laws.

9. Tenant has obtained all necessary governmental licenses and permits required to lawfully conduct its business at the Premises, including, but not limited to, business, department of health, and safety licenses or permits.

10. Tenant has not assigned or otherwise transferred its interest in the Lease to any party or sublet any portion of the Premises.

11. By the terms of the Lease, Tenant has the option to renew the Lease for two (2) additional periods, beginning on the day next following the expiration date of the initial seven (7) year Lease term and continuing for five (5) years thereafter for each such additional period.

Except as may be amended herein, all terms and conditions of the Lease shall continue in full force and effect and are hereby republished, ratified, and reaffirmed in their entirety. This Certificate shall be binding upon and may be relied upon by the parties hereto and their respective legal representatives, successors, and assigns.

IN WITNESS WHEREOF, the parties have executed this Certificate as of the day and year first above written.

LANDLORD:

V.A. CLINIC ASSOCIATES,  
a Nevada limited partnership

By: Mark L. Fine  
General Partner

TENANT:

UNIVERSITY OF NEVADA SCHOOL OF MEDICINE  
MULTI-SPECIALTY GROUP PRACTICE SOUTH, INC.,  
a Nevada corporation

By: David V. Schapira, M.D., President

APPROVED:

University of Nevada School of Medicine  
Integrated Clinical Services, Inc., a Nevada corporation

By: Robert M. Daugherty M.D., Ph.D., President



EXHIBIT E-1

SUBORDINATION, ATTORNMENT AND NON-DISTURBANCE AGREEMENT

THIS AGREEMENT is made as of \_\_\_\_\_, 1998, by and among V.A. CLINIC ASSOCIATES ("Landlord") and UNIVERSITY OF NEVADA SCHOOL OF MEDICINE MULTI-SPECIALTY GROUP PRACTICE SOUTH, INC. ("Tenant"), and \_\_\_\_\_ (the "Beneficiary") whose address is \_\_\_\_\_

A. The Property. The term "Property", as used herein, shall mean the real property situated in the County of Clark, State of Nevada, legally described in Exhibit "A" attached hereto and by this reference made a part hereof, together with all buildings, structures, improvements and fixtures now or hereafter located thereon, and together with all easements and other rights appurtenant thereto.

B. The Lease. Pursuant to the terms and provisions of a lease dated \_\_\_\_\_, between Landlord and Tenant (the "Lease"), for an initial term of five (5) years, the Property has been leased to Tenant.

C. The Loan; Security Documents; Deed of Trust. Landlord proposes to borrow certain sums from Beneficiary to be evidenced by a promissory note. Landlord proposes to encumber the Property as security for payment of its obligations to Beneficiary and, for such purpose, shall enter into various instruments and documents (collectively the "Security Documents"), including without limitation a Deed of Trust and Security Agreement (the "Deed of Trust") from Landlord for the use and benefit of the Beneficiary and an Assignment of Landlord's Interest in Lease (the "Collateral Assignment"), which Deed of Trust and Collateral Assignment will be recorded in the real property records of Clark County, Nevada.

D. Purposes. In connection with the above-mentioned transactions, Landlord and Tenant have agreed to offer certain assurances and representations to the Beneficiary, and all parties agree to provide for (i) the subordination of the Lease to the Security Documents; (ii) the continuation of the Lease notwithstanding any foreclosure of the Deed of Trust subject to certain conditions; and (iii) Tenant's attornment to the Beneficiary or to such other parties as may acquire title to the Property as the result of any foreclosure or any conveyance of the Property in lieu of foreclosure.

AGREEMENT

NOW, THEREFORE, in consideration of the mutual terms and provisions hereinafter contained and other good and valuable consideration received by any party from any other, the receipt and sufficiency of which are hereby acknowledged, the parties agree as follows:

1. Notices of Default to Beneficiary. Notwithstanding anything to the contrary contained in the Lease, Tenant shall personally deliver or mail to Beneficiary, at Beneficiary's address set forth above, written notice of any default under the Lease by Landlord, and if within the time provided in the Lease for curing thereof by Landlord, Beneficiary performs or causes to be performed all such obligations with respect to which Landlord is in default which can be cured by the payment of money, any right of Tenant to terminate the Lease by reason of such default shall cease and be null and void.

VM 



2. Subordination of Lease to Security Documents. Tenant hereby subordinates its leasehold estate in the Property and all of Tenant's right under the Lease to the Security Documents and to all extensions, renewals, modifications, consolidations and replacements thereof, to the full extent of all obligations secured or to be secured thereby including interest thereon and any future advances thereunder.

3. Non-Disturbance of Tenant. Beneficiary agrees that, for so long as Tenant shall perform and satisfy all obligations of Tenant under the Lease in accordance with its terms, neither the Lease nor Tenant's rights pursuant thereto shall be disturbed or affected by any foreclosure of the Deed of Trust or conveyance in lieu of foreclosure.

4. Beneficiary as Landlord after Foreclosure. In the event that Beneficiary (or any other party) shall acquire title to the Property or shall succeed to Landlord's interest in the Lease, whether through foreclosure of the Deed of Trust, conveyance in lieu of foreclosure, or otherwise, Beneficiary (or such other party) shall thereupon, and without the necessity of attornment or other act or agreement, be substituted as Tenant's landlord under the Lease, and shall be entitled to the rights and benefits and subject to the obligations thereof; provided that neither Beneficiary nor any other party shall be:

- (a) liable for any act or omission of any prior landlord under the Lease (including Landlord); or
- (b) subject to any offsets or defenses which Tenant might have against any prior landlord (including Landlord) except those which arose out of such landlord's default under the Lease and accrued after Tenant notified Beneficiary and gave it the opportunity to cure required in the Lease; or
- (c) bound by Tenant's payment of any rent or additional rent beyond the then current rent period to any prior landlord under the Lease (including Landlord); or
- (d) bound by any amendment, modification, extension or supplement of the Lease made without Beneficiary's prior written consent;

and Tenant hereby agrees to attorn to and recognize such Beneficiary (or such other party) as Tenant's landlord.

5. Payment of Rent Upon Default. Tenant has been advised that the Security Documents give Beneficiary the right to collect rent and other sums payable under the Lease directly from Tenant upon the occurrence of a default thereunder, and that upon the receipt from Beneficiary of notice of any such default, Tenant will thereafter pay all rent and other sums payable under the Lease directly (or as Beneficiary shall direct) as they become due and payable.

6. Application of Insurance and Condemnation Proceeds. Tenant has been advised that the insurance and condemnation provisions of the Security Documents give Beneficiary certain rights to require that insurance and condemnation proceeds be applied to payment of the indebtedness secured thereby and not to restoration or rebuilding; and Tenant hereby waives any terms of such Lease with respect to the application of insurance and condemnation proceeds which are inconsistent with the terms of the Security Documents.

7. Binding Effect. The provisions of this Agreement shall be covenants running with the Property, and shall be binding upon and shall inure to the benefits of the parties hereto and their respective heirs, representatives, successors and assigns.

MM JS  
PLEASE INITIAL

IN WITNESS WHEREOF, the parties have executed this Agreement as of the day and year first above written.

LANDLORD:

V.A. CLINIC ASSOCIATES,  
a Nevada limited partnership

\_\_\_\_\_  
Mark L. Fine, General Partner

TENANT:

UNIVERSITY OF NEVADA SCHOOL OF MEDICINE  
MULTI-SPECIALTY GROUP PRACTICE SOUTH, INC.,  
a Nevada corporation

\_\_\_\_\_  
By: David V. Schapira, M.D., President

APPROVED:  
University of Nevada School of Medicine  
Integrated Clinical Services, Inc.,  
a Nevada corporation

\_\_\_\_\_  
By: Robert M. Daugherty M.D., Ph.D., President



EXHIBIT "E-2"

**CONSENT TO SUB-LEASE, ATTORNMENT AND NON-DISTURBANCE AGREEMENT**

THIS CONSENT TO SUB-LEASE, ATTORNMENT AND NON-DISTURBANCE AGREEMENT (this "Agreement") is made this \_\_\_\_ day of \_\_\_\_\_, \_\_\_\_ by and among SANDRA BUSHROE and LINDA MAY ZOELLER, successors-in-interest to DODD SMITH (collectively with its assignee(s), "Landlord"), V.A. CLINIC ASSOCIATES, a Nevada limited partnership, successor-in-interest to MARCUS R. DURLACH, III (collectively, with its assignee(s), "Tenant") and UNIVERSITY OF NEVADA SCHOOL OF MEDICINE MULTI-SPECIALTY GROUP PRACTICE SOUTH, INC. ("Sub-Tenant") with respect to:

(i) that certain Lease Agreement dated August 16, 1978 (the "Main Lease," and the premises subject thereto, the "Premises") made by and between Landlord and Tenant; and (ii) that certain Lease Agreement dated \_\_\_\_\_ made by and between Landlord and Tenant; and (iii) such other leases or sub-leases after the termination of the Sub-Lease (collectively with the Sub-Lease, the "Sub-Leases") which Tenant may enter into during the term of the Main Lease with other sub-tenants, after termination of the Sub-Lease (collectively with Sub-Tenant, the "Sub-Tenants").

NOW, THEREFORE, the parties agree as follows:

1. *Consent to Sub-Leases; Subordination.* Landlord hereby consents to the Sub-Leases of the Premises to Sub-Tenants.

2. *Attornment; payments after Tenant default.* Sub-Tenants shall attorn to and recognize the Landlord as the Landlord under the Main Lease, for the unexpired balance (and any extensions, if exercised) of the Sub-Leases, effective on the date the Sub-Tenants receive notice from the Landlord that the Tenant is in default under the Main Lease. After receipt of such notice from Landlord, Tenant agrees that Sub-Tenants may pay to Landlord, or at the direction of Landlord, all monies due or to become due to Landlord under the Main Lease. Tenant hereby waives any right, claim, or demand it may now have or hereafter have against Sub-Tenants by reason of such payment(s) under the Main Lease to Landlord, and any such payment(s) shall discharge and reduce the obligation of Sub-Tenants to pay rent to Tenant under the Sub-Leases, as to the amount of such payment(s) made directly to Landlord.

3. *Non-Disturbance.* If the Main Lease is terminated for any reason prior to the expiration of its term, such termination shall not terminate nor affect the validity of the Sub-

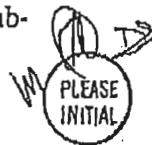



FIRST AMENDMENT

THIS FIRST AMENDMENT (the "First Amendment") is entered into this \_\_\_ day of \_\_\_\_\_, 2009, by and between V.A. CLINIC ASSOCIATES, a Nevada limited partnership ("Landlord") UNIVERSITY OF NEVADA SCHOOL OF MEDICINE MULTI-SPECIALTY GROUP PRACTICE SOUTH, INC., a Nevada corporation ("Tenant").

RECITALS:

A. Landlord and Tenant entered into that certain Lease Agreement dated January 20, 1998 (the "Lease"), for a building located at 1703 West Charleston Blvd., City of Las Vegas, County of Clark, State of Nevada (as more specifically defined therein; the "Premises"). Capitalized terms used herein and not otherwise defined shall have the meanings which are set forth in the Lease.

B. Landlord and Tenant have agreed to amend the Lease as set forth herein.

NOW THEREFORE, based upon the covenants and promises contained herein and other good and valuable consideration, Landlord and Tenant mutually agree as follows:

1. The date by which Tenant must exercise its second option to extend, if at all, pursuant to Article 2 of the Lease is hereby postponed from November 30, 2009 to and until May 31, 2010. The purpose of such postponement shall be to allow Landlord and Tenant to enter into discussions concerning additional renewal options and other matters affecting the Lease (the "Lease Discussions").

2. The Term of the Lease is hereby extended for an extension period beginning on December 1, 2010 and continuing to and until the earlier of (i) May 31, 2011, or (ii) the date which is three hundred eighty-five (385) days after either Landlord or Tenant gives notice to the other that it is withdrawing from further Lease Discussions (which either party shall the right to do at any time in its sole and absolute discretion) (the "Extension Period").

3. During the Extension Period, Landlord shall have no obligation to make repairs described in Paragraphs 11(a) or 11(b) of the Lease, but all other terms and conditions of the Lease shall continue to apply.

4. Except as modified herein, the Lease shall remain in full force and effect.

IN WITNESS WHEREOF, this First Amendment has been executed on the day and year above written.

"LANDLORD"

V.A. CLINIC ASSOCIATES,  
A Nevada limited partnership

By: \_\_\_\_\_  
Name: Mark L. Fine  
Its: General Partner

"TENANT"

UNIVERSITY OF NEVADA SCHOOL OF MEDICINE  
MULTI-SPECIALTY GROUP PRACTICE SOUTH, INC.,  
A Nevada corporation

By:   
Name: Ronald M. Zurek  
Its: Vice President for Administration and Finance

"LANDLORD"

V.A. CLINIC ASSOCIATES,  
A Nevada limited partnership

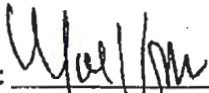
By:   
Name: Mark L. Fine  
Its: General Partner

"TENANT"

UNIVERSITY OF NEVADA SCHOOL OF MEDICINE  
MULTI-SPECIALTY GROUP PRACTICE SOUTH, INC.,  
A Nevada corporation

By: \_\_\_\_\_  
Name: \_\_\_\_\_  
Its: \_\_\_\_\_



SECOND AMENDMENT

THIS SECOND AMENDMENT (the "Second Amendment") is entered into this 1<sup>st</sup> day of June, 2010, by and between V.A. CLINIC ASSOCIATES, a Nevada limited partnership ("Landlord"), and UNIVERSITY OF NEVADA SCHOOL OF MEDICINE MULTI-SPECIALTY GROUP PRACTICE SOUTH, INC., a Nevada corporation ("Tenant").

RECITALS:

A. Landlord and Tenant entered into that certain Lease Agreement dated January 20, 1998 (as amended by a certain First Amendment dated as of January 18, 2010, the "Lease"), for a building located at 1703 West Charleston Blvd., City of Las Vegas, County of Clark, State of Nevada (as more specifically defined therein, the "Premises"). Capitalized terms used herein and not otherwise defined shall have the meanings which are set forth in the Lease.

B. Landlord and Tenant have agreed to amend the Lease as set forth herein.

NOW THEREFORE, based upon the covenants and promises contained herein and other good and valuable consideration, Landlord and Tenant mutually agree as follows:

1. By its execution of this Second Amendment, Tenant is exercising its second option to extend the term of the Lease, and the term of the Lease is hereby extended, for an extension term beginning on June 1, 2011 and expiring on May 31, 2016 (the "Extension Term").

2. Pursuant to Article 4 of the Lease and Paragraph 3 of the First Amendment, monthly rent shall increase on December 1, 2010 to \$66,550 per month. On December 1, 2015, monthly rent shall increase by ten percent (10%) to \$73,205 per month.

3. Tenant is hereby given the option to extend the term of the Lease on all of the provisions contained in the Lease, except for fixed rent, which shall be determined pursuant to Paragraph 4 below, and except for Landlord's repair obligations, which shall be amended pursuant to Paragraph 5 below, for two (2) additional consecutive periods of five (5) years following the expiration of the Extension Term; provided that on the date the applicable extended term is to commence Tenant shall not be in default under this Lease (after receipt by Tenant of any notice required under the terms of this Lease and beyond any cure period provided for in this Lease and after an additional notice, stating Landlord's intent to cancel the extension of the Lease by Tenant as a result of such default, and the lapse of an additional twenty (20) days without cure by Tenant after such additional notice). To exercise the first such option to extend, Tenant shall give Landlord written notice of exercise of such option no later than May 31, 2015. To exercise the second such option to extend, Tenant shall give Landlord written notice of exercise of such option no later than May 31, 2020. Notwithstanding anything to the contrary contained in this Lease, if Tenant fails to give any such notice of exercise within the time provided herein, Tenant shall not be deemed to have waived the applicable option to extend

unless and until Landlord shall have given Tenant written notice of such failure and such failure continues for a period for twenty (20) days after Tenant's receipt of such notice. In the event that on the date the applicable extended term is to commence Tenant shall be in default under this Lease (after receipt by Tenant of any notice required under the terms of this Lease and beyond any cure period provided for in this Lease), at Landlord's option, the extended term shall not commence and this Lease shall thereupon expire. All references in this Lease to the term shall mean the initial term, as extended by the Extension Term and as further extended by any option pursuant to this paragraph.

4. If Tenant exercises its first renewal option pursuant to Paragraph 3 above, monthly rent shall increase by ten percent (10%) to \$80,525 on December 1, 2020. If Tenant exercises its second renewal option pursuant to Paragraph 3 above, monthly rent shall increase by ten percent (10%) to \$88,578 on December 1, 2025.

5. If Tenant exercises its first renewal option pursuant to Paragraph 3 above, then, effective as of the commencement of that renewal option term on June 1, 2016, the amount of Twenty-Five Hundred Dollars (\$2,500) set forth in Paragraphs 11(a) and 11(b) of the Lease shall increase to Forty-Five Hundred Dollars (\$4,500) (hereinafter the "Repair Threshold Amount"). On June 1, 2017 and on June 1 of each year thereafter during the term of the Lease as the same may be extended, the Repair Threshold Amount shall increase by three and one-half percent (3.5%) of the Repair Threshold Amount in effect for the prior year.

6. Concurrently with the execution of this Second Amendment, Landlord and Tenant and University of Nevada, Reno, which is an affiliate of Tenant, shall execute an Option Agreement and Escrow Instructions granting Tenant and such affiliate the option to purchase the Premises and a right of first offer to purchase the Premises upon the terms and subject to the conditions which are set forth therein.

7. Except as modified herein, the Lease shall remain in full force and effect.

8. This Second Amendment may be executed in any number of counterparts, each of which shall be deemed an original, and all of which together shall constitute one agreement. This Second Amendment, signed and transmitted by facsimile machine or pdf file, is to be treated as an original document and the signature of any party hereon, if so transmitted, is to be considered as an original signature, and the document so transmitted is to be considered to have the same binding effect as a manually executed original.

IN WITNESS WHEREOF, this Second Amendment has been executed on the day and year above written.

[Signatures on Next Page]

"LANDLORD"

V.A. CLINIC ASSOCIATES,  
A Nevada limited partnership

By:   
Name: Mark L. Fine  
Its: General Partner

"TENANT"

UNIVERSITY OF NEVADA SCHOOL OF MEDICINE  
MULTI-SPECIALTY GROUP PRACTICE SOUTH, INC.,  
A Nevada corporation

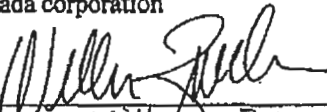
By:   
Name: William Zamboni  
Its: MSA(S) UNISON



### THIRD AMENDMENT

THIS THIRD AMENDMENT (the "Third Amendment") is entered into this 16 day of March, 2014,<sup>5</sup> by and between V.A. CLINIC ASSOCIATES, a Nevada limited partnership ("Landlord"), and UNIVERSITY OF NEVADA SCHOOL OF MEDICINE MULTI-SPECIALTY GROUP PRACTICE SOUTH, INC., a Nevada corporation ("Tenant").

#### RECITALS:

A. Landlord and Tenant entered into that certain Lease Agreement dated January 20, 1998, as amended by a certain First Amendment dated as of January 18, 2010 and that certain Second Amendment dated as of June 1, 2010 (collectively, the "Lease"), for a Building located at 1707 West Charleston Blvd., City of Las Vegas, County of Clark, State of Nevada (as more specifically defined therein, the "Premises"), upon a portion of the Land located at 1703-1707 W. Charleston Boulevard, Las Vegas, Nevada, and more particularly described in the Lease, consisting of approximately 2.79 acres. Capitalized terms used herein and not otherwise defined shall have the meanings which are set forth in the Lease.

B. Tenant wishes to construct a stairway and ramp to provide access to and from the Building and other premises leased by Tenant in the building located at 1701 W. Charleston Boulevard, as shown on Exhibit "A" attached hereto and by this reference made a part hereof ("Stairway/Ramp"). Landlord is willing to approve the Stairway/Ramp, provided that Tenant agrees to the terms and conditions hereof.

NOW THEREFORE, based upon the covenants and promises contained herein and other good and valuable consideration, Landlord and Tenant mutually agree as follows:

1. Construction. Tenant agrees to construct the Stairway/Ramp (the "Tenant Work") in a good and workmanlike manner in and upon the Land, at Tenant's sole cost and expense, in accordance with the following provisions. Tenant shall submit to Landlord for Landlord's approval complete plans and specifications for the construction of the Tenant Work ("Tenant's Plan"). Within 10 business days after receipt of Tenant's Plan, Landlord shall review and either approve or disapprove Tenant's Plan. If Landlord disapproves Tenant's Plan, or any portion thereof, Landlord shall notify Tenant thereof and of the revisions Landlord requires before Landlord will approve Tenant's Plan. Within 10 business days after Landlord's notice, Tenant shall submit to Landlord, for Landlord's review and approval, plans and specifications incorporating the required revisions. The final plans and specifications approved by Landlord are hereinafter referred to as the "Approved Construction Documents". Tenant will employ experienced, licensed contractors, architects, engineers and other consultants, to construct the Tenant Work and will require in the applicable contracts that such parties (a) carry insurance in such amounts and types of coverages as are reasonably required by Landlord, and (b) design and construct the Tenant Work in a good and workmanlike manner and in compliance with all applicable laws, including, without limitation, the Americans with Disabilities Act (the "ADA"). Tenant shall obtain from its contractors and provide to Landlord a list of all subcontractors

providing labor or materials in connection with any portion of the Tenant Work prior to commencement of the Tenant Work. Tenant warrants that the design, construction and installation of the Tenant Work shall conform to the requirements of all applicable laws (including, without limitation, the ADA) and the requirements of any authority having jurisdiction over, or with respect to, such Tenant Work. Tenant shall reimburse Landlord, within fifteen (15) days after written demand therefor, for all reasonable out-of-pocket costs and expenses which may be incurred by Landlord in connection with the Stairway/Ramp, including without limitation, architect's fees charged for the review of Tenant's Plan and attorneys' fees incurred in connection with the preparation of this Third Amendment.

2. **Lien Waivers.** Tenant shall provide to Landlord (i) third-party invoices for costs incurred by Tenant in constructing the Tenant Work; (ii) evidence that Tenant has paid the invoices for such costs; and (iii) lien waivers from any contractor or supplier who has constructed or supplied materials for the Tenant Work. Tenant agrees to keep the Building and the Land free from any liens arising out of the construction of the Tenant Work.

3. **Assumption of Risk and Waiver.** FOR THE TERM OF THE LEASE, TENANT HEREBY ASSUMES ANY AND ALL RISKS INVOLVED WITH RESPECT TO THE TENANT WORK AND HEREBY RELEASES AND DISCHARGES LANDLORD FROM ANY AND ALL LIABILITY OR LOSS, DAMAGE OR INJURY SUFFERED OR INCURRED BY TENANT OR THIRD PARTIES IN ANY WAY ARISING OUT OF OR IN CONNECTION WITH THE TENANT WORK.

4. **Insurance.** Tenant shall maintain a commercial general liability insurance policy covering Tenant's liability related to bodily injury and property damages arising from the Tenant Work. Tenant shall have the Landlord named as an additional insured on such insurance policy and shall provide Landlord proof of such status prior to construction of the Tenant Work.

5. **Maintenance.** Once constructed, the Stairway/Ramp shall be considered a leasehold improvement and shall be maintain by Tenant in good working order and free from waste, litter and any condition that is offensive to the public health, safety and welfare.

6. **Removal.** Upon the expiration or earlier termination of the Lease, Landlord shall have the right to require Tenant to remove the Stairway/Ramp, restore any damage caused by such removal and repair and restore the landscaping, curbing, signage and other improvements upon the Land to substantially the same condition as existed immediately prior to the Tenant Work (collectively, the "**Removal Work**"), all at Tenant's cost and expense. If Landlord does not require removal of the Stairway/Ramp upon the expiration or earlier termination of the Lease, the Stairway/Ramp shall become the sole property and responsibility of the Landlord. The Removal Work, if required by Landlord, shall be completed within thirty (30) days after the expiration or earlier termination of the Lease in accordance with plans for such work which are prepared and stamped by a licensed structural engineer engaged by Tenant (if and to the extent reasonably required by the matters of such work) and which are otherwise acceptable to Landlord and a permit for such work from the appropriate authority shall be obtained by Tenant. The Removal Work shall not be deemed to be completed until Tenant delivers to Landlord (i) a certificate from Tenant's licensed structural engineer stating that such work has been completed in accordance with the approved plans, and (ii) proof of final inspection and approval from the appropriate authority. In the alternative, Landlord may elect to have Landlord's contractor perform the Removal Work at Tenant's cost. If Landlord elects to have Landlord's contractor

perform such work, Tenant shall pay the cost thereof, including all fees for permits and engineering and architectural services incurred by Landlord in connection with the Removal Work, within thirty (30) days after invoice from Landlord. Tenant's obligations in this Section 6 shall survive the expiration or earlier termination of the Lease.

7. **Effect of Amendment.** Except as modified herein, the Lease shall remain in full force and effect.

8. **Counterparts.** This Third Amendment may be executed in any number of counterparts, each of which shall be deemed an original, and all of which together shall constitute one agreement. This Third Amendment, signed and transmitted by facsimile machine or pdf file, is to be treated as an original document and the signature of any party hereon, if so transmitted, is to be considered as an original signature, and the document so transmitted is to be considered to have the same binding effect as a manually executed original.

IN WITNESS WHEREOF, this Third Amendment has been executed on the day and year above written.

"LANDLORD"

V.A. CLINIC ASSOCIATES,  
A Nevada limited partnership

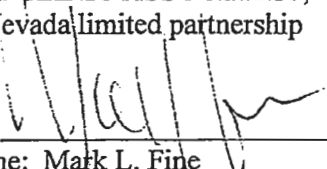
By:   
Name: Mark L. Fine  
Its: General Partner

"TENANT"

UNIVERSITY OF NEVADA SCHOOL OF MEDICINE  
MULTI-SPECIALTY GROUP PRACTICE SOUTH, INC.,  
A Nevada corporation

By: \_\_\_\_\_  
Name: \_\_\_\_\_  
Its: \_\_\_\_\_



perform such work, Tenant shall pay the cost thereof, including all fees for permits and engineering and architectural services incurred by Landlord in connection with the Removal Work, within thirty (30) days after invoice from Landlord. Tenant's obligations in this Section 6 shall survive the expiration or earlier termination of the Lease.

7. Effect of Amendment. Except as modified herein, the Lease shall remain in full force and effect.

8. Counterparts. This Third Amendment may be executed in any number of counterparts, each of which shall be deemed an original, and all of which together shall constitute one agreement. This Third Amendment, signed and transmitted by facsimile machine or pdf file, is to be treated as an original document and the signature of any party hereon, if so transmitted, is to be considered as an original signature, and the document so transmitted is to be considered to have the same binding effect as a manually executed original.

IN WITNESS WHEREOF, this Third Amendment has been executed on the day and year above written.

"LANDLORD"

V.A. CLINIC ASSOCIATES,  
A Nevada limited partnership

By: \_\_\_\_\_  
Name: Mark L. Fine  
Its: General Partner

"TENANT"

UNIVERSITY OF NEVADA SCHOOL OF MEDICINE  
MULTI-SPECIALTY GROUP PRACTICE SOUTH, INC.,  
A Nevada corporation

By:   
Name: Elissa J. Palmer, MD  
Its: MSAS Vice President

EXHIBIT A

DESCRIPTION OF STAIRWAY/RAMP

[to be attached]



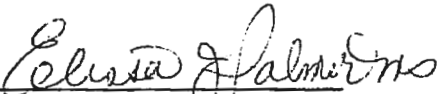

W. CHARLESTON BLVD.

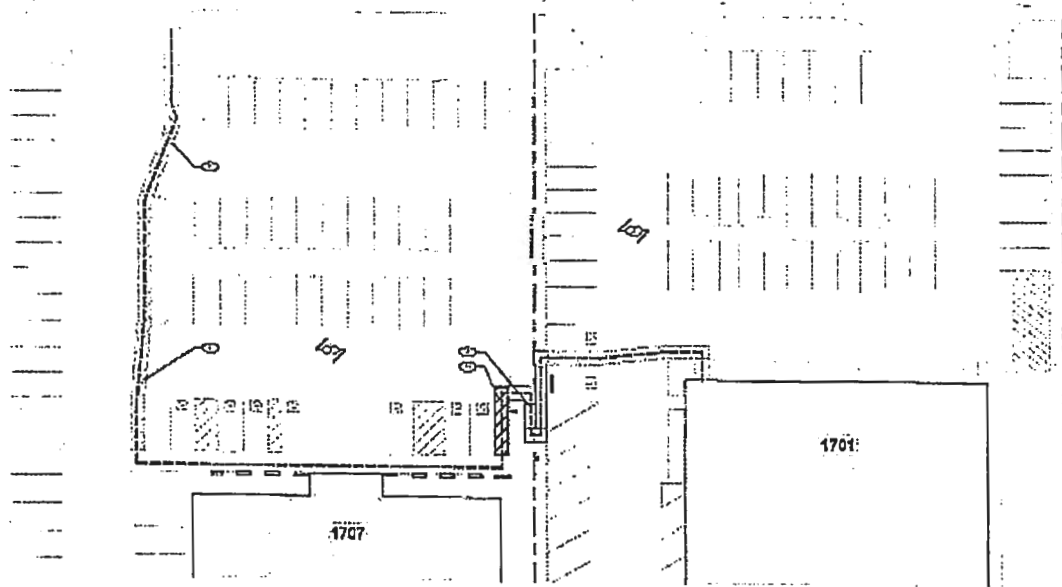

B SITE  
SCALE 1/4" = 1'-0"

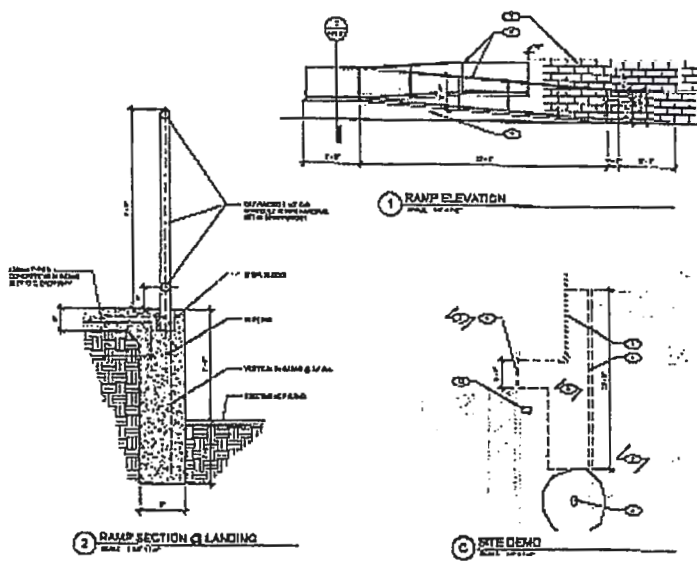

1 RAMP ELEVATION  
SCALE 1/4" = 1'-0"

2 RAMP SECTION & LANDING  
SCALE 1/4" = 1'-0"

C SITE DEMO  
SCALE 1/4" = 1'-0"

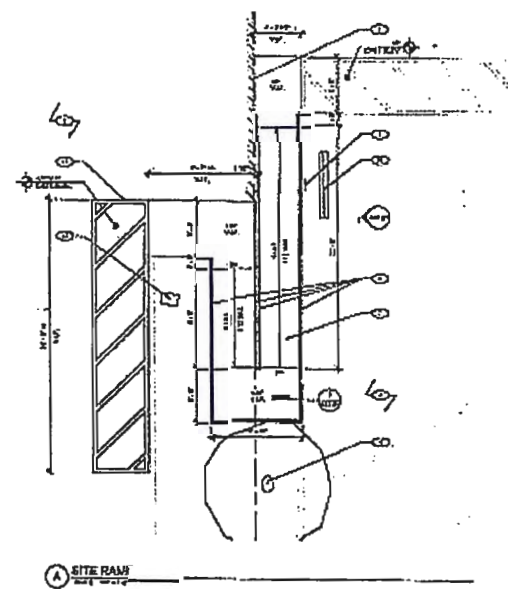

A SITE RAMP  
SCALE 1/4" = 1'-0"

**GENERAL NOTES**

1. SEE PRELIMINARY CONTRACT DOCUMENTS FOR ALL NOTES.
2. ALL WORK SHALL BE IN ACCORDANCE WITH THE LATEST EDITIONS OF THE IBC AND ALL APPLICABLE LOCAL ORDINANCES.
3. THE CONTRACTOR SHALL BE RESPONSIBLE FOR OBTAINING ALL NECESSARY PERMITS AND APPROVALS FROM THE APPROPRIATE AGENCIES.
4. THE CONTRACTOR SHALL MAINTAIN ACCESS TO ALL ADJACENT PROPERTIES AT ALL TIMES.
5. THE CONTRACTOR SHALL BE RESPONSIBLE FOR PROTECTING ALL EXISTING UTILITIES AND STRUCTURES.
6. THE CONTRACTOR SHALL MAINTAIN ADEQUATE RECORDING OF ALL WORK PERFORMED.
7. THE CONTRACTOR SHALL BE RESPONSIBLE FOR THE PROTECTION OF ALL EXISTING TREES AND LANDSCAPE.
8. THE CONTRACTOR SHALL MAINTAIN ADEQUATE SAFETY MEASURES THROUGHOUT THE PROJECT.
9. THE CONTRACTOR SHALL BE RESPONSIBLE FOR THE PROTECTION OF ALL ADJACENT PROPERTIES.
10. THE CONTRACTOR SHALL MAINTAIN ADEQUATE RECORDING OF ALL WORK PERFORMED.
11. THE CONTRACTOR SHALL BE RESPONSIBLE FOR THE PROTECTION OF ALL EXISTING TREES AND LANDSCAPE.
12. THE CONTRACTOR SHALL MAINTAIN ADEQUATE SAFETY MEASURES THROUGHOUT THE PROJECT.

**REVISIONS**

1. CORRECT ACCESSIBLE ROUTE TO PUBLIC WAY
2. CORRECT FINISH
3. CORRECT CURB WALL TO FORM
4. CORRECT TRAILER STATION
5. CORRECT LANDING
6. CORRECT RAMP SLOPE AND COP PROTECTION DEPTH IN DEMO AREA
7. CORRECT DISTANCE FROM
8. CORRECT CURB TO RAMP
9. CORRECT FINISH MATERIAL TO CURB AND RAMP
10. CORRECT LANDSCAPE PROTECTION
11. CORRECT ACCESSIBLE PARKING SPOTS
12. CORRECT CURB
13. CORRECT RAMP SLOPE AND FINISH TO MEET LANDING
14. CORRECT CURB AND RAMP PROTECTION

**TATE SNYDER KIMSEY**

1701 W. CHARLESTON

**SITE PLAN / SITE DEMO / SITE RAMP**

**UNR - ACCESSIBLE RAMP**

1701 W. CHARLESTON

AS1.01